

TECHNICAL MANUAL
UNIT, INTERMEDIATE DIRECT
SUPPORT
AND INTERMEDIATE GENERAL
SUPPORT
MAINTENANCE INSTRUCTIONS
BOWTHRUSTER WATERJET

FOR
LANDING CRAFT UTILITY (LCU)
NSN 1905-01-154-1191

INTRODUCTION 1-1

UNIT MAINTENANCE
INSTRUCTIONS 2-1

APPENDIXES A-1

ALPHABETICAL
INDEX INDEX-1

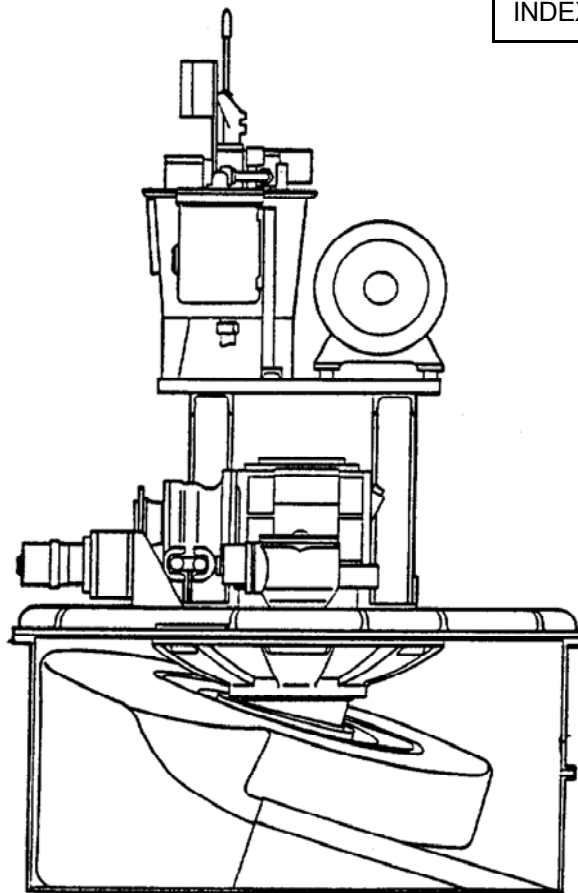

Approved for public release. Distribution is unlimited.

HEADQUARTERS, DEPARTMENT OF THE ARMY
17 JANUARY 1989

WARNING

MODIFICATION HAZARD

Unauthorized modifications, alterations or installations of or to this equipment are prohibited and are in violation of AR 750-10. Any such unauthorized modifications, alterations or installations could result in death, injury or damage to the equipment

**HIGH PRESSURE
HYDRAULIC SYSTEM HAZARDS**

Hydraulic systems can cause serious injuries if high pressure lines or equipment fail.

Never work on hydraulic systems or equipment unless there is another person nearby who is familiar with the operation and hazards of the equipment, and who can give first aid. A second person should stand by controls to turn off hydraulic pumps in an emergency. When the technicians are aided by the operators, the operators must be warned about dangerous areas.

MOVING MACHINERY HAZARDS

Be very careful when operating or working near moving machinery.

Running engines, rotating shafts, and other moving machinery parts could cause personal injury or death.

ELECTRICAL HAZARDS

Whenever possible, the power supply to the equipment must be shut off before beginning work on the equipment. Do not be misled by the term "low voltage." Potentials as low as 50 volts may cause death under adverse conditions.

Be careful not to contact 115-Vac input connections when installing or operating this equipment.

For Artificial Respiration, refer to FM 4-25.11.

CHANGE

NO. 3

HEADQUARTERS
DEPARTMENT OF THE ARMY
WASHINGTON, D.C., 30 September 2005

UNIT, INTERMEDIATE DIRECT SUPPORT AND
INTERMEDIATE GENERAL SUPPORT
MAINTENANCE INSTRUCTIONS

BOWTHRUSTER WATERJET
FOR
LANDING CRAFT, UTILITY (LCU)
NSN 1905-01-154-1191

DISTRIBUTION STATEMENT A: Approved for public release, distribution is unlimited

TM 55-1905-223-24-6, 17 January 1989, is changed as follows:

1. Remove and insert pages as indicated below. New or changed text material is indicated by a vertical bar in the margin. An illustration change is indicated by a miniature pointing hand.

Remove pages	Insert pages
.....	A/(B blank)
i and ii	i and ii
1-1 and 1-2	1-1 and 1-2
1-15 and 1-16	1-15 and 1-16
2-17 and 2-18	2-17 and 2-18
2-19 and 2-20	2-19/(2-20 blank)
2-21 through 2-24	2-21 through 2-24
2-29 and 2-30	2-29 and 2-30
B-3 through B-6	B-3 through B-6
B-7 and B-8
C-1 and C-2	C-1 and C-2

2. Retain this sheet in front of manual for reference purposes.

By Order of the Secretary of the Army:

PETER J. SCHOOMAKER
General, United States Army
Chief of Staff

Official:

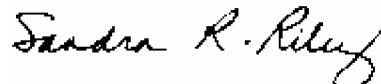

SANDRA R. RILEY
Administrative Assistant to the
Secretary of the Army
0510808

DISTRIBUTION:

To be distributed in accordance with the Initial Distribution Number (IDN) 253580, requirements for TM 55-1905-223-24-6.

CHANGE

NO. 2

HEADQUARTERS
DEPARTMENT OF THE ARMY
WASHINGTON, D.C., 4 April 1994

Unit Maintenance Instructions
BOWTHRUSTER WATERJET
for
LANDING CRAFT, UTILITY (LCU)
NSN 1905-01-154-1191

DISTRIBUTION STATEMENT A: Approved for public release, distribution is unlimited

TM 55-1905-223-24-6, 17 January 1989, is changed as follows:

1. Title is changed as shown above.
2. Remove and insert pages as indicated below. New or changed text material is indicated by a vertical bar in the margin. An illustration change is indicated by a miniature pointing hand.

Remove pages

Insert pages

i and i
B-1 through B-6

i and ii
B-1 through B-6

3. Retain this sheet in front of manual for reference purposes.

By Order of the Secretary of the Army:

Official:

GORDON R. SULLIVAN
General, United States Army
Chief of Staff

MILTON H. HAMILTON
Administrative Assistant to the
Secretary of the Army
06513

DISTRIBUTION:

To be distributed in accordance with DA Form 12-25-E, block no. 3580, requirements for TM 55-1905-223-24-6.

CHANGE

NO. 1

HEADQUARTERS,
DEPARTMENT OF THE ARMY
WASHINGTON, D.C., 11 August 1990

Unit, Intermediate Direct Support and
Intermediate General Support
Maintenance Instructions
BOWTHRUSTER WATERJET
for
LANDING CRAFT, UTILITY (LCU)
NSN 1905-01-154-1191

Approved for public release; distribution is unlimited.

TM 55-1905-223-24-6, 17 January 1989, is changed as follows:

1. Remove and insert pages as indicated below. New or changed text material is indicated by a vertical bar in the margin. An illustration change is indicated by a miniature pointing hand.

Remove pages	Insert pages
2-23 and 2-24	2-23 and 2-24
2-27 through 230	2-27 through 2-30
B-5 through B9/B-10	B-5 through B-8

2. Retain this sheet in front of manual for reference purposes.

By Order of the Secretary of the Army:

CARL E. VUONO
General, United States Army
Chief of Staff

Official:

WILLIAM J. MEEHAN, 11
Brigadier General, United States
The Adjutant General

DISTRIBUTION:

To be distributed in accordance with DA Form 12-25E, Unit and Direct Support and General Support Maintenance requirements for Landing Craft, Utility, LUC-1466, Type III.

INSERT LATEST CHANGED PAGES. DESTROY SUPERSEDED DATA.

LIST OF EFFECTIVE PAGES

Note: The portion of text affected by the changes is indicated by a vertical line in the outer margins of the page. Changes to illustrations are indicated by miniature pointing hands. Changes to wiring diagrams are indicated by shaded areas.

Date of issue for the original manual and changed pages are:

Original	0	17 January 1989	Change	2	4 April 1994
Change	1	11 August 1990	Change	3	30 September 2005

TOTAL NUMBER OF PAGES IS 85 CONSISTING OF THE FOLLOWING:

Page No.	*Change No.	Page No.	*Change No.
Cover	1	2-28	0
a/(b blank)	0	2-29	3
i.....	3	2-30 through 2-32.....	0
ii.....	0	2-33/(2-34 blank)	0
1-1 and 1-2.....	3	A-1/(A-2 blank)	0
1-3 through 1-14.....	0	B-1 through B-3	2
1-15.....	3	B-4.....	3
1-16 through 1-24.....	0	B-5.....	2
2-1 through 2-16	0	B-6.....	3
2-17 and 2-18.....	3	B-7 and B-8 Deleted.....	3
2-19/(2-20 blank)	3	C-1.....	0
2-21	3	C-2.....	3
2-22 and 2-23	0	D-1/(D-2 blank)	0
2-24	3	Glossary 1 through Glossary 6	0
2-25 and 2-26.....	0	Index 1 and Index 2	0
2-27	1		

*Zero in this column indicates an original page.

**UNIT, INTERMEDIATE DIRECT SUPPORT AND
INTERMEDIATE GENERAL SUPPORT
MAINTENANCE INSTRUCTIONS**

**BOWTHRUSTER WATERJET
FOR
LANDING CRAFT UTILITY (LCU)
NSN 1905-01-154-1191**

REPORTING ERRORS AND RECOMMENDING IMPROVEMENTS

You can help improve this publication. If you find any mistakes or if you know of a way to improve the procedures, please let us know. Submit your DA Form 2028 (Recommended Changes to Equipment Technical Publications), through the Internet, on the Army Electronic Product Support (AEPS) website. The Internet address is <https://aeaps.ria.army.mil>. The DA Form 2028 is located under the Public Applications section in the AEPS Public Home Page. Fill out the form and click on SUBMIT. Using this form on the AEPS will enable us to respond quicker to your comments and better manage the DA Form 2028 program. You may also mail, fax or E-mail your letter or DA Form 2028 direct to: AMSTA-LC-LMIT / TECH PUBS, TACOM-RI, 1 Rock Island Arsenal, Rock Island, IL 61299-7630. The email address is TACOM-TECH-PUBS@ria.army.mil. The fax number is DSN 793-0726 or Commercial (309) 782-0726.

DISTRIBUTION STATEMENT A: Approved for public release; distribution is unlimited.

TABLE OF CONTENTS

	<u>PAGE</u>
CHAPTER 1	INTRODUCTION 1-1
Section I	General Information 1-1
Section II	Equipment Description and Data 1-3
Section III	Principles of Operation 1-22
CHAPTER 2	UNIT MAINTENANCE INSTRUCTIONS 2-1
Section I	Repair Parts; Special Tools; Test, Measurement, and Diagnostic Equipment (TMDE); and Support Equipment 2-1
Section II	Service Upon Receipt 2-1
Section III	Unit Preventive Maintenance Checks and Services (PMCS) 2-2
Section IV	Unit Maintenance Troubleshooting Procedures 2-14
Section V	Unit Maintenance Procedures 2-17
Section VI	Preparation for Storage or Reshipment, and Return to Service 2-32

TABLE OF CONTENTS - Continued

APPENDIX A	REFERENCES	A-1
APPENDIX B	MAINTENANCE ALLOCATION CHART	B-1
APPENDIX C	EXPANDABLE/DURABLE SUPPLIES AND MATERIALS LIST	C-1
APPENDIX D	TORQUE VALUES	D-1
GLOSSARY	ABBREVIATIONS AND DEFINITIONS	Glossary 1
ALPHABETICAL INDEX	Index 1

CHAPTER 1
INTRODUCTION

	Page
Section I. General Information.....	1-1
Section II. Equipment Description and Data	1-3
Section III. Principles of Operation	1-22

Section I. GENERAL INFORMATION

1-1. **Scope.** The scope of this manual is as follows:

- a. Type of Manual. Unit, Intermediate Direct Support and Intermediate General Support Maintenance Instructions.
- b. Name of Equipment: Bowthruster waterjet, Model SPJ-55 (FIGURE 1-1) installed aboard the LCU 2000 Class watercraft.
- c. Purpose of Equipment. Provides steerable thrust at the bow for maneuvering the vessel in close quarters.

1-2. **Maintenance Forms, Records, and Reports.** Department of the Army forms and procedures used for equipment maintenance are prescribed by DA Pam 738-750, the Army Maintenance Management System.

1-3. **Destruction of Army Materiel.** Refer to TM 750-244-3 for instructions covering the destruction of Army materiel to prevent enemy use.

1-4. **Reporting Equipment Improvement Recommendations (EIR).** If any component in your system needs improvement, let us know. Send us an EIR. You, the user, are the only one who can tell us what you don't like about your equipment. Let us know why you don't like the design or performance. If you have Internet access, the easiest and fastest way to report problems or suggestions is to go to <https://aeps.ria.army.mil/aepspublic.cfm> (scroll down and choose the "Submit Quality Deficiency Report" bar). The Internet form lets you choose to submit an Equipment Improvement Recommendation (EIR), a Product Quality Deficiency Report (PQDR) or Warranty Claim Action (WCA). You may also submit your information using an SF 368 via e-mail, regular mail, or facsimile using the addresses/facsimile numbers specified in DA PAM 738-750, Functional Users Manual for the Army Maintenance Management System (TAMMS). We will send you a reply.

1-5. **Preparation for Storage or Shipment.** Administrative storage of equipment issued to and used by Army activities will have preventive maintenance performed in accordance with the Preventive Maintenance Checks and Services (PMCS) charts before storing. When removing the equipment from administrative storage, the PMCS should be performed to assure operational readiness. Preparation of equipment for shipment or short term storage is covered in paragraphs 2-15 and 2-16.

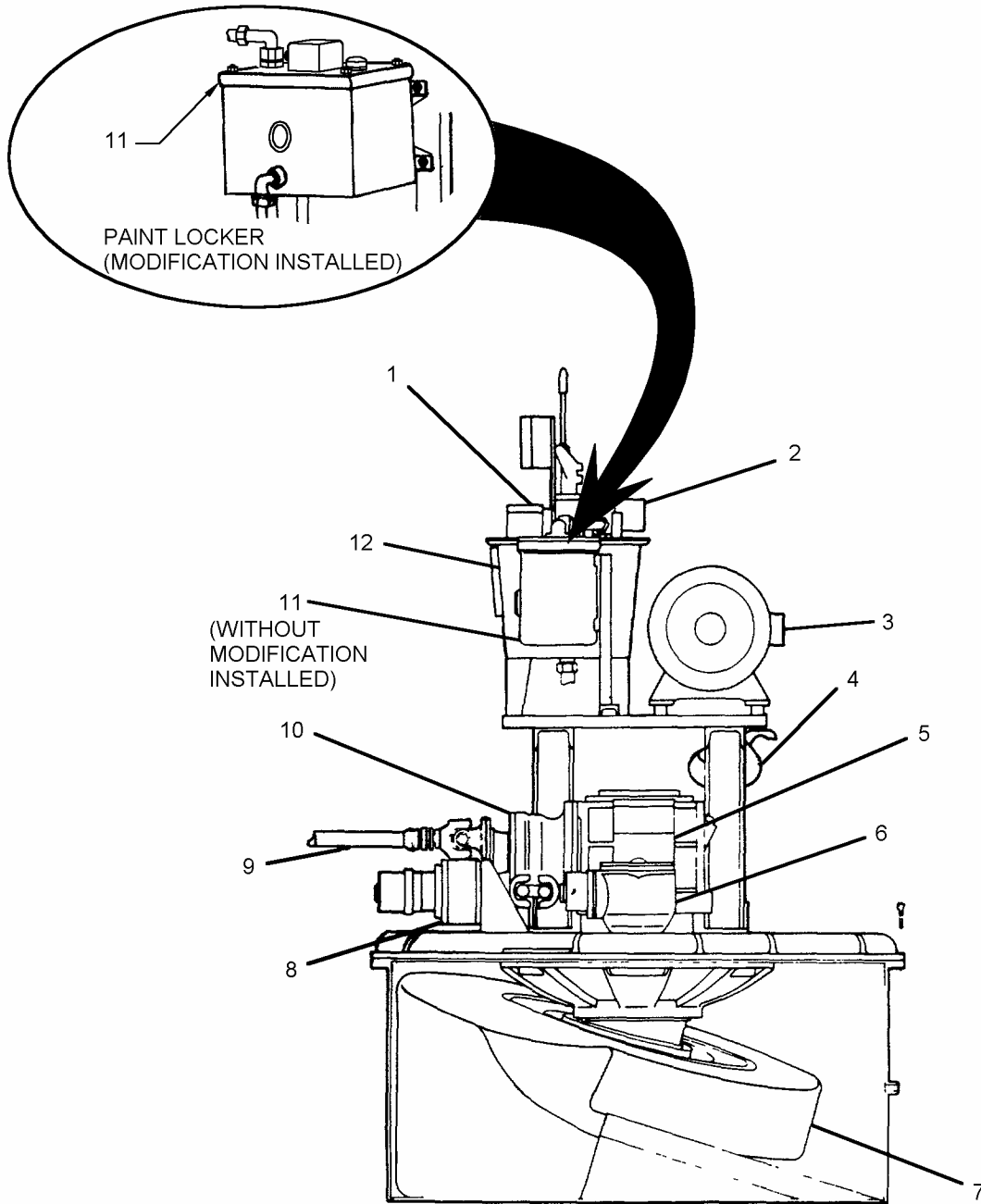

LEGEND

- | | |
|-------------------------------|--|
| 1. OIL RETURN FILTER ASSEMBLY | 7. WATERJET ASSEMBLY |
| 2. HYDRAULIC AGGREGATE | 8. STEERING ASSEMBLY |
| 3. PUMP ASSEMBLY | 9. DRIVE SHAFT |
| 4. OIL EVACUATION PUMP | 10. UPPER GEAR ASSEMBLY |
| 5. FEEDBACK UNIT | 11. LUBE OIL TANK ASSEMBLY |
| 6. STEERING GEAR ASSEMBLY | 12. HYDRAULIC AGGREGATE
BASE ASSEMBLY |

FIGURE 1-1. Model SPJ-55 Bowthruster Waterjet.

Section II. EQUIPMENT DESCRIPTION AND DATA

1-6. **General.** The bowthruster system installed aboard the LCU 2000Class watercraft is a Schottel Model SPJ-55 steerable waterjet powered by a 300 horsepower Cummins Model NT855M diesel engine. Operation of this jet applies directionally controlled thrust near the bow to help maneuver the vessel in close quarters.

1-7. **Characteristics, Capabilities, and Features.** A very broad view of the bowthruster waterjet is as follows:

a. Characteristics.

- (1) Both a propulsion and steering system.
- (2) High volume jet pump provides propulsion.
- (3) Used with ship's twin propellers and rudders.

b. Capabilities and Features.

- (1) Ejects seawater through a steerable nozzle.
- (2) Bowthruster engine is also auxiliary fire pump.
- (3) Controls are at ship control console in pilothouse and in bowthruster room.

1-8. **Location and Description of Major Components.** (FIGURES 1-2 and 1-3). The bowthruster waterjet is a high displacement centrifugal water pump. System machinery includes drive shafting to the pump plus steering machinery for the nozzle. This machinery is integrated into a compact unit installed in the bowthruster room. The well cover is the watertight closure and the structural support for both the external and internal components.

a. Hull Interface. The waterjet is installed over a cylindrical well (FIGURE 1-2) in the ship's bottom. This protects external components from grounding damage. A grid over the intake throat protects the impeller from trash ingestion. An upper flange forms the foundation for the waterjet.

b. Bowthruster Engine Interface. The bowthruster engine is installed between the bowthruster waterjet (forward) and fire pump No. 1 (aft) (FIGURE 1-3). Power takeoff couplings and independently operated clutches allow the same engine to power either the waterjet or the fire pump. Engine controls and primary waterjet controls are remotored to the ship control console in the pilothouse.

c. Drive Shaft. (FIGURE 1-4). A drive shaft transfers engine torque to the waterjet upper gear assembly. This steel tube has a U-joint at each end. One bolts to a flexible coupling on the engine power takeoff shaft (FIGURE 1-5). The other incorporates a flange which mates with the drive flange of the upper gear assembly. One end of the tube also includes a spline. Grease fittings are provided at each U-joint and at the spine.

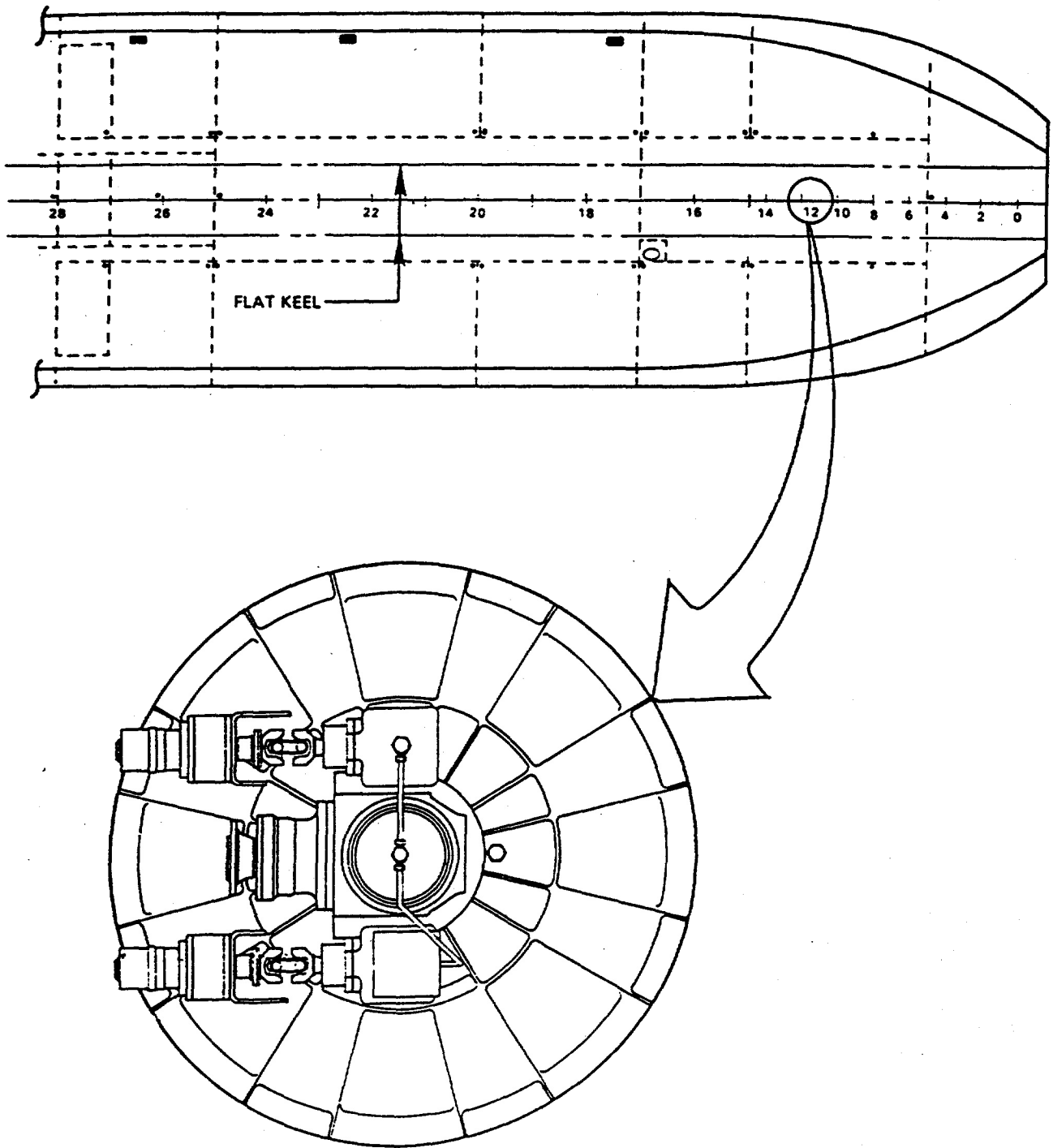

FIGURE 1-2. Installation Plan View.

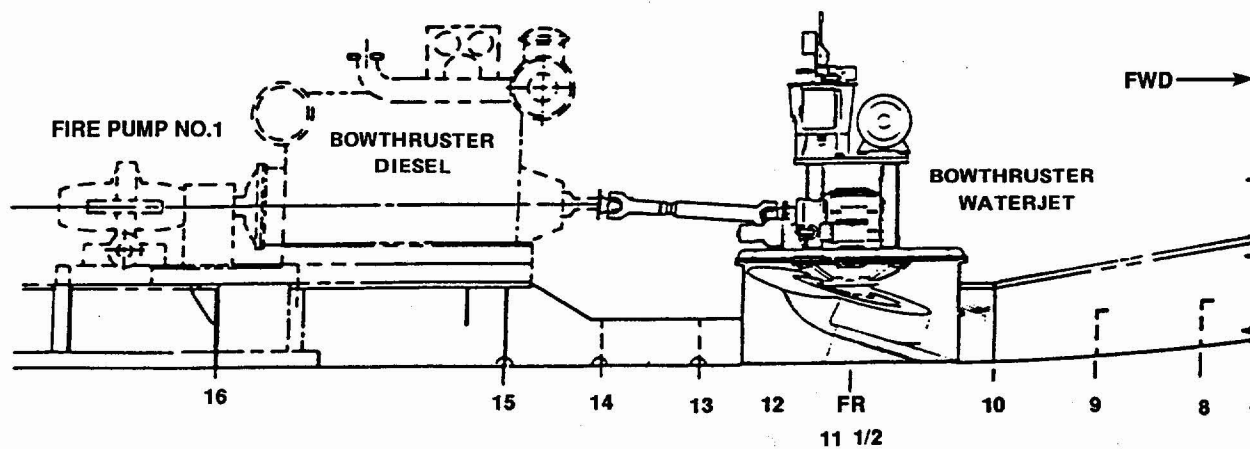
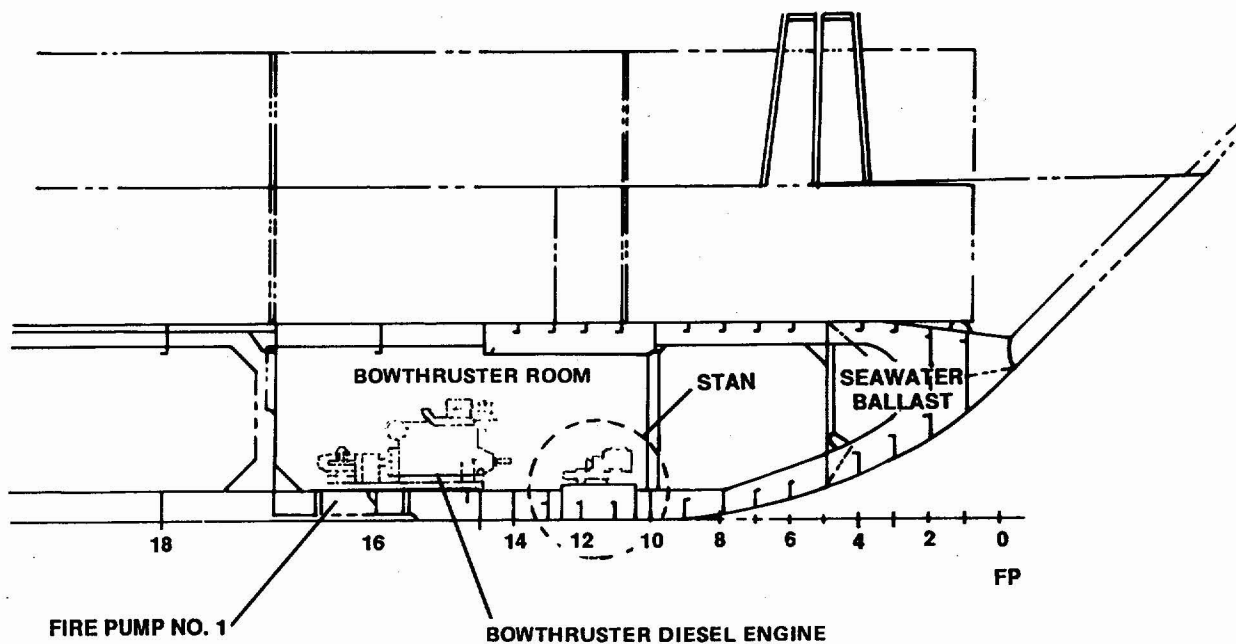

FIGURE 1-3. Installation Profile.

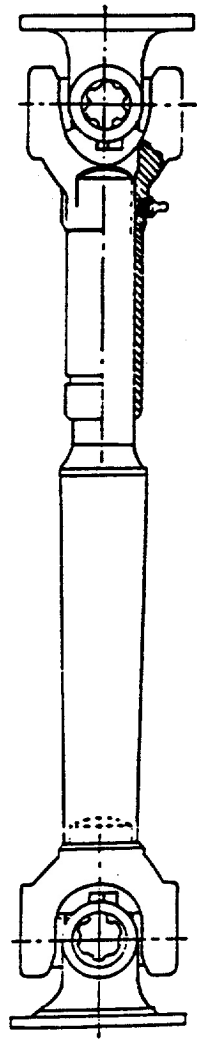

FIGURE 1-4. Drive Shaft.

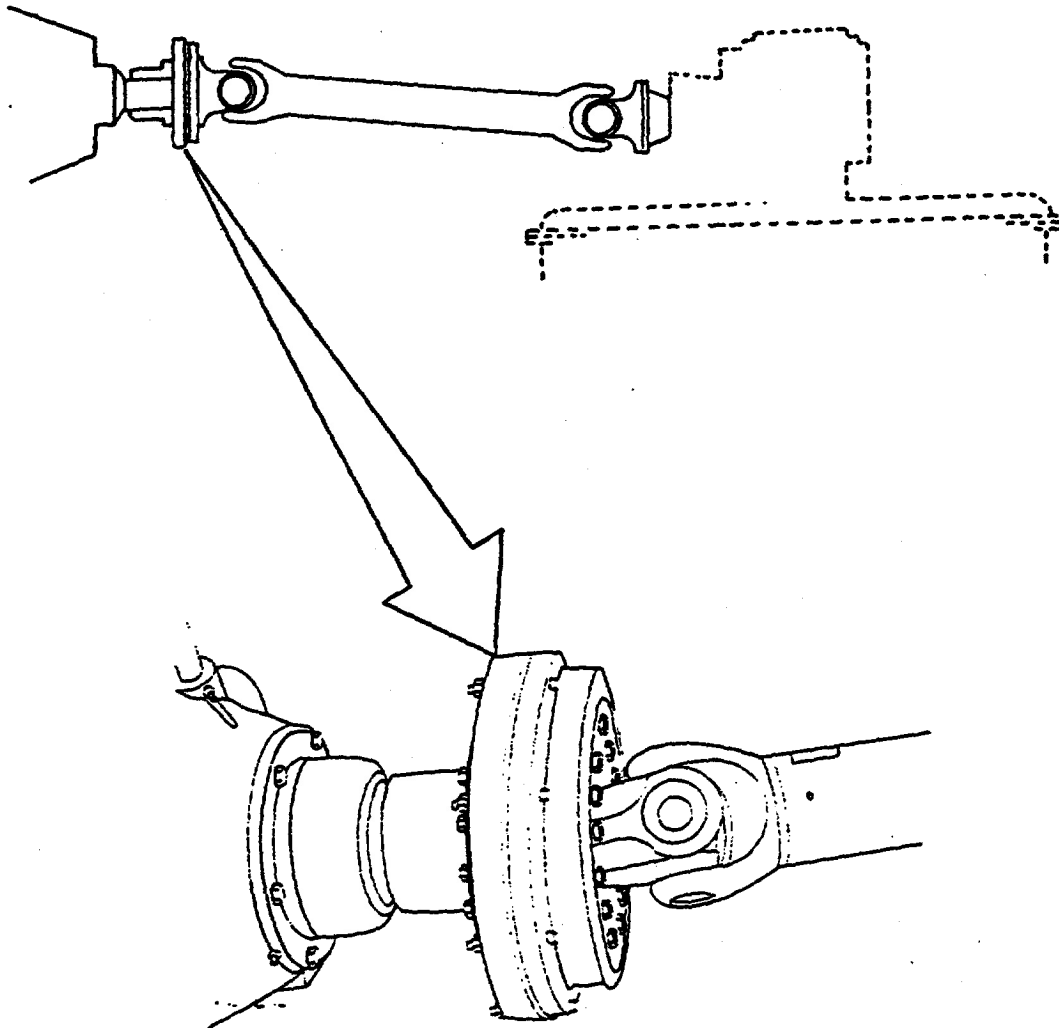

FIGURE 1-5. Engine Interface.

d. Pilothouse Interface. (FIGURE 1-6). The pilothouse is the primary control station for operating the bowthruster waterjet. The pilot steers the bowthruster by right or left hand pressure on the joy stick control lever on the Bow Ramp, Winch, Thruster Control Console. This lever activates steering gear hydraulics to turn the waterjet casing clockwise or counterclockwise depending on the command. When released, the steering control joy stick returns to the neutral position and the casing is mechanically locked at the angle shown on the thrust direction indicator. Engine and clutch controls and displays are discussed in the bowthruster engine manual. Console controls and displays for the waterjet are listed below. For additional details on the console refer to TM 55-1905-223-10 the operator's manual for the LCU. (See Appendix A.)

Controls are:

SCHOTTEL UNIT ON (Key Switch)
(Green) HYDRAULIC PUMP ON (Rotary Switch)
(Green) STEERING PORT STARBOARD (Joy Stick)
(dial and LAMP CHECK (Push Button)
HORN OFF (Push Button)

Displays are:

SCHOTTEL UNIT ON
HYDRAULIC PUMP ON
THRUST DIRECTION
pointer)
MIN OIL LEVEL HY-TANK
(Red lamp plus alarm horn)
MIN LUB OIL LEVEL SPJ
(Red lamp plus alarm horn)

e. Electrical Power. (FIGURE 1-7). The bowthruster waterjet requires 220- volt, 3-phase, 60 Hertz ac power from the ship's electrical system into the water jet terminal box mounted over the hydraulic tank. The primary load is the 20 horsepower hydraulic pump motor. Power is also required for sensors indicators, controls, and alarms. Cabling for these functions is shown in FIGURE 1-7.

f. Upper Gear Assembly. (FIGURE 1-8). The waterjet mechanically couples the bowthruster engine to the jet pump impeller. The upper gear assembly is an oil filled gear box mounted on the well cover containing a matched pair of speed reducing bevel gears and associated bearings. The gears convert horizontal shaft input torque to vertical shaft output torque. The output shaft drives the impeller as described below.

g. Waterjet Assembly. (FIGURE 1-9). This assembly includes the well cover plus associated waterjet components within the well. The impeller shaft drives the rotor assembly to which the impeller wheel is bolted. The entire assembly including the surrounding inlet and discharge casings is inclined 15 degrees to give a downward slope to the waterjet discharge. This rake is established by the design of the steering tube. Within the tube are two universal joints on the lower impeller shaft to accommodate this angular change. The impeller wheel spans the inclined throat of the flared inlet casing and forces water upward and outward into the discharge spiral and nozzle.

h. Steering Gear. (FIGURE 1-10). The steering gear controls thrust direction by rotating the entire jet pump casing. This casing forms a volute which turns as a unit within the well enclosure. Included are the downward flared inlet to the inclined impeller wheel and the spiral configured outlet and discharge nozzle. Steering torque is applied at the steering tube to which these components are attached. A bevel gear fitted to the upper collar of the steering tube engages drive pinions of the right and left steering gear boxes. The tube and gear surround the impeller drive components but turn independently. Matching hydraulic motors drive the input shafts of these right and left gear boxes. The right gear box incorporates a geared takeoff to the rudder angle transmitter.

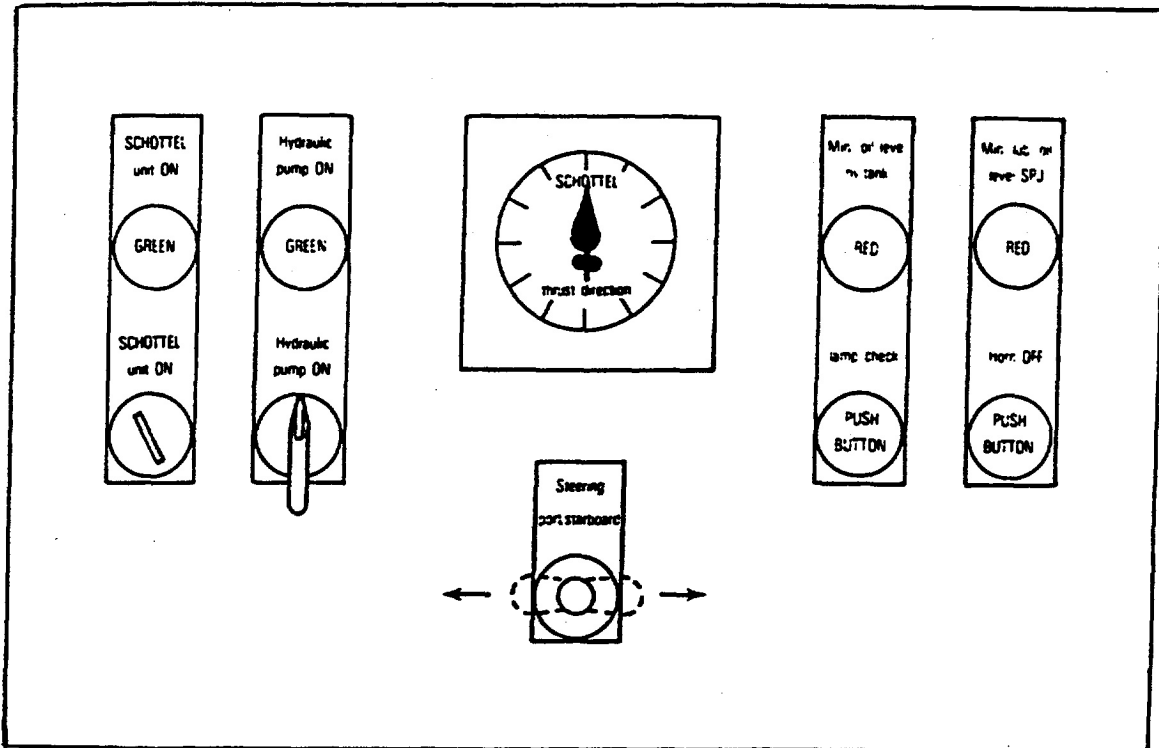

FIGURE 1-6. Pilothouse Control Panel.

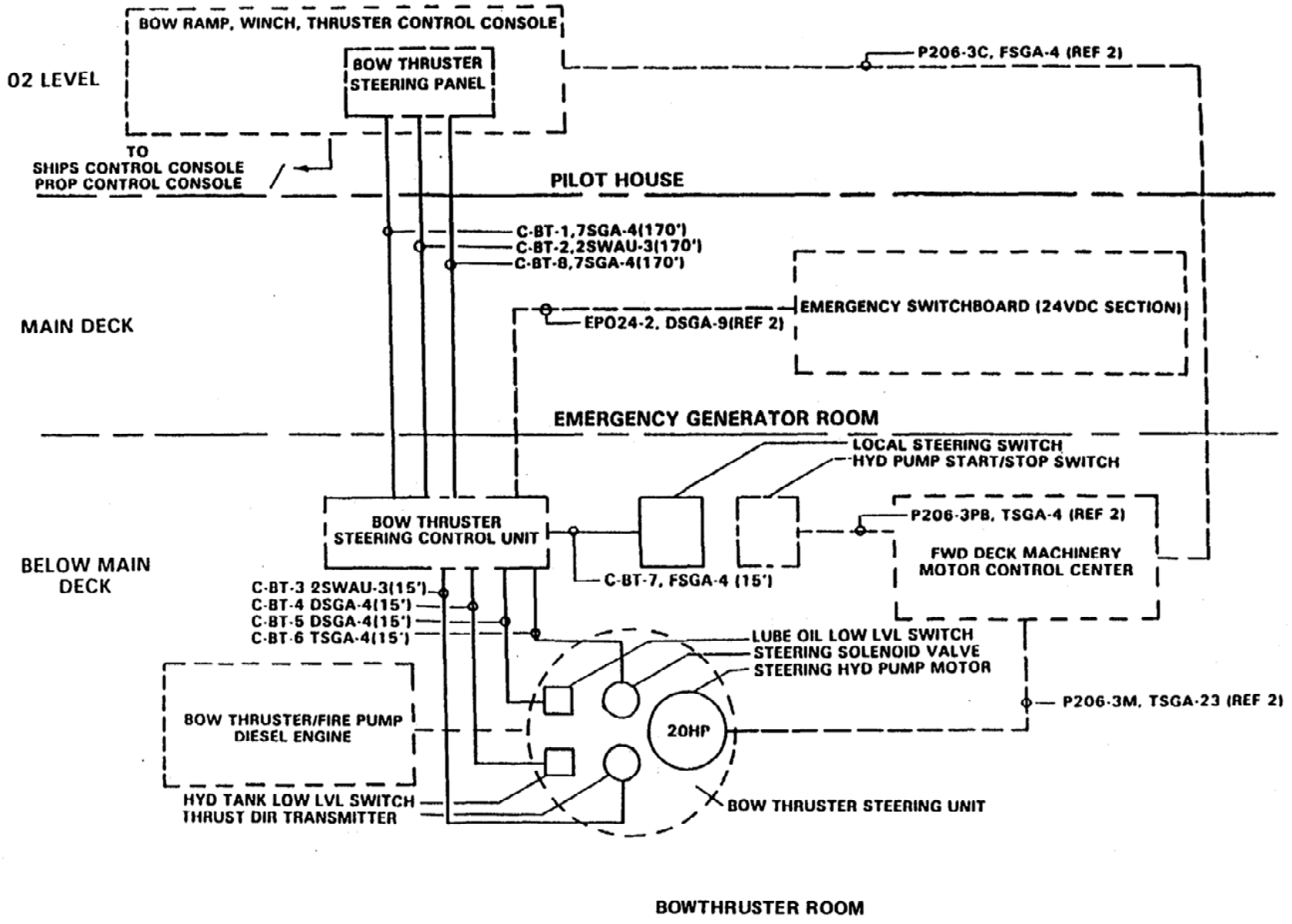

FIGURE 1-7. Cable Interconnecting Diagram (Sheet 1 of 2).

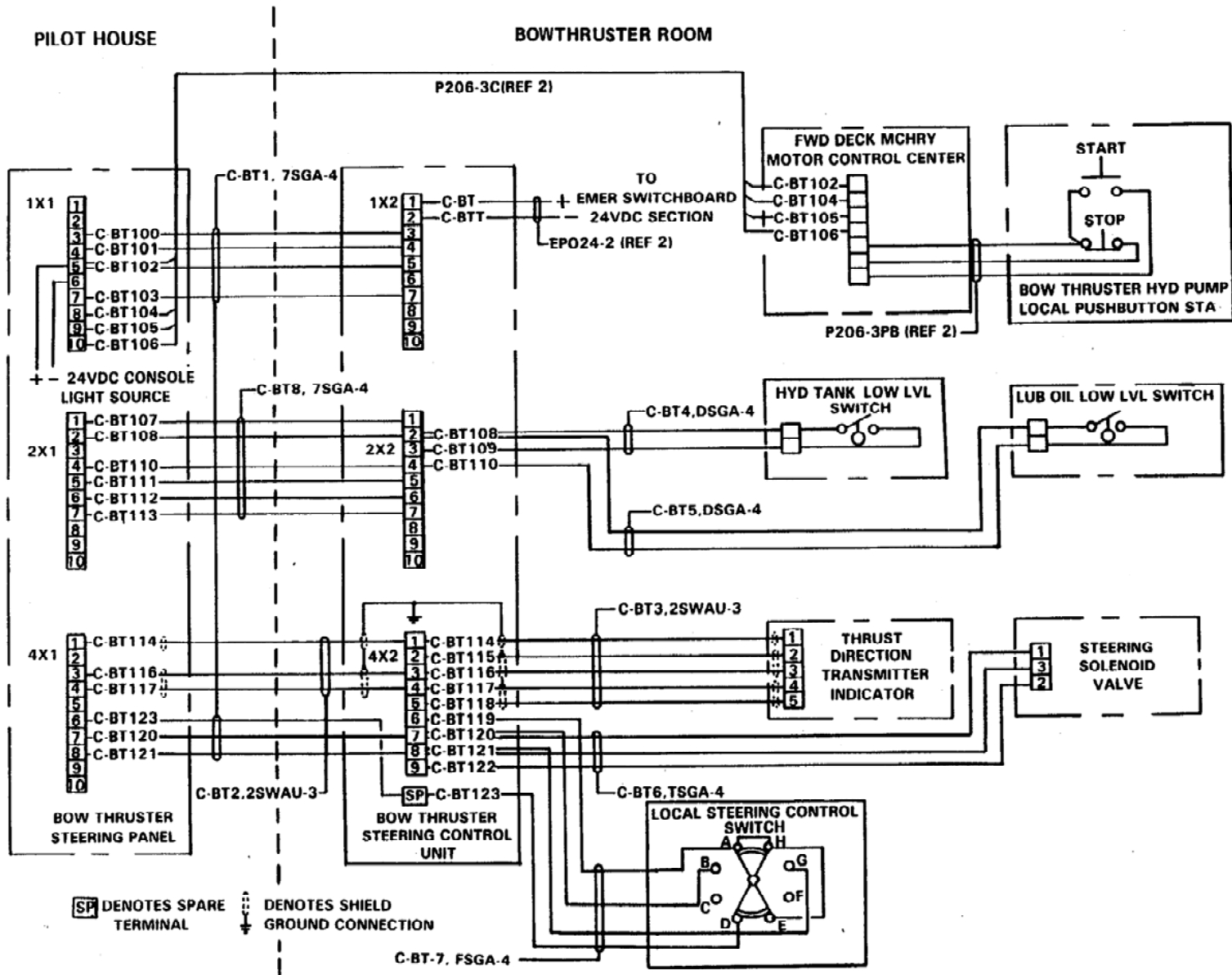

FIGURE 1-7. Cable Interconnecting Diagram (Sheet 2 of 2).

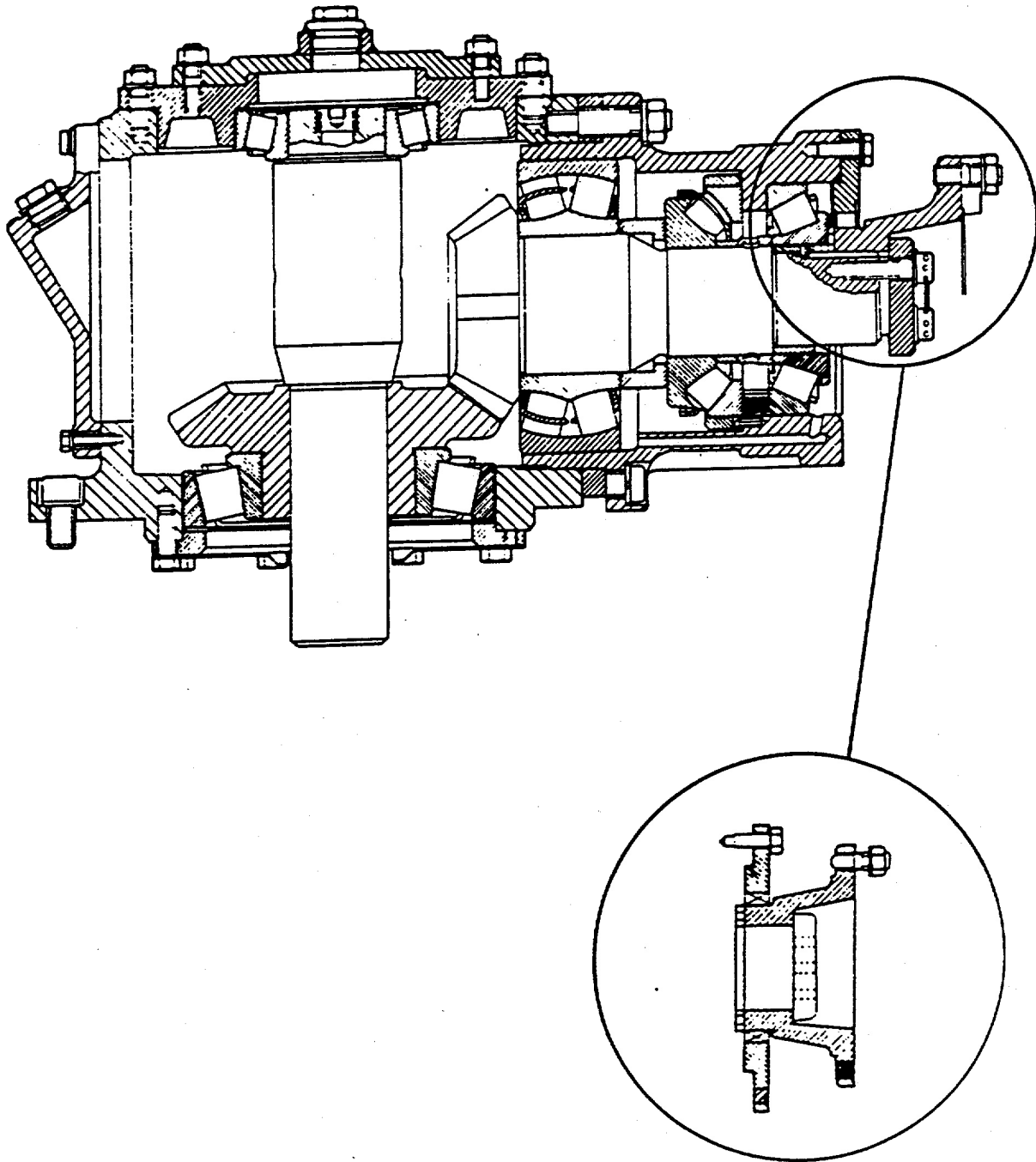

FIGURE 1-8. Upper Gear Assembly.

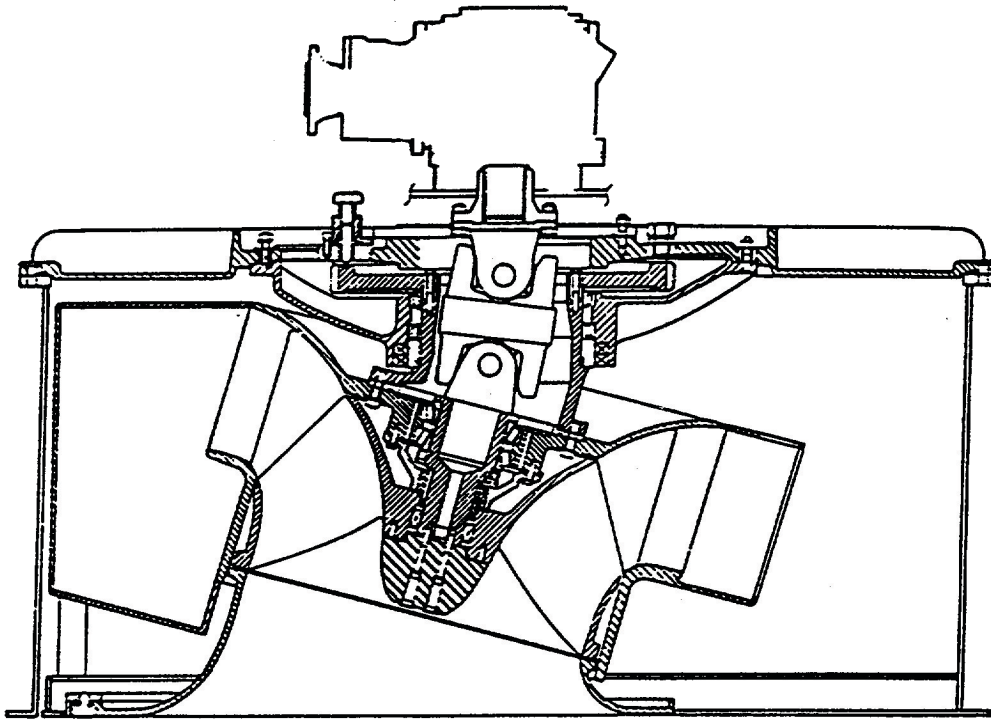

FIGURE 1-9. Waterjet Assembly.

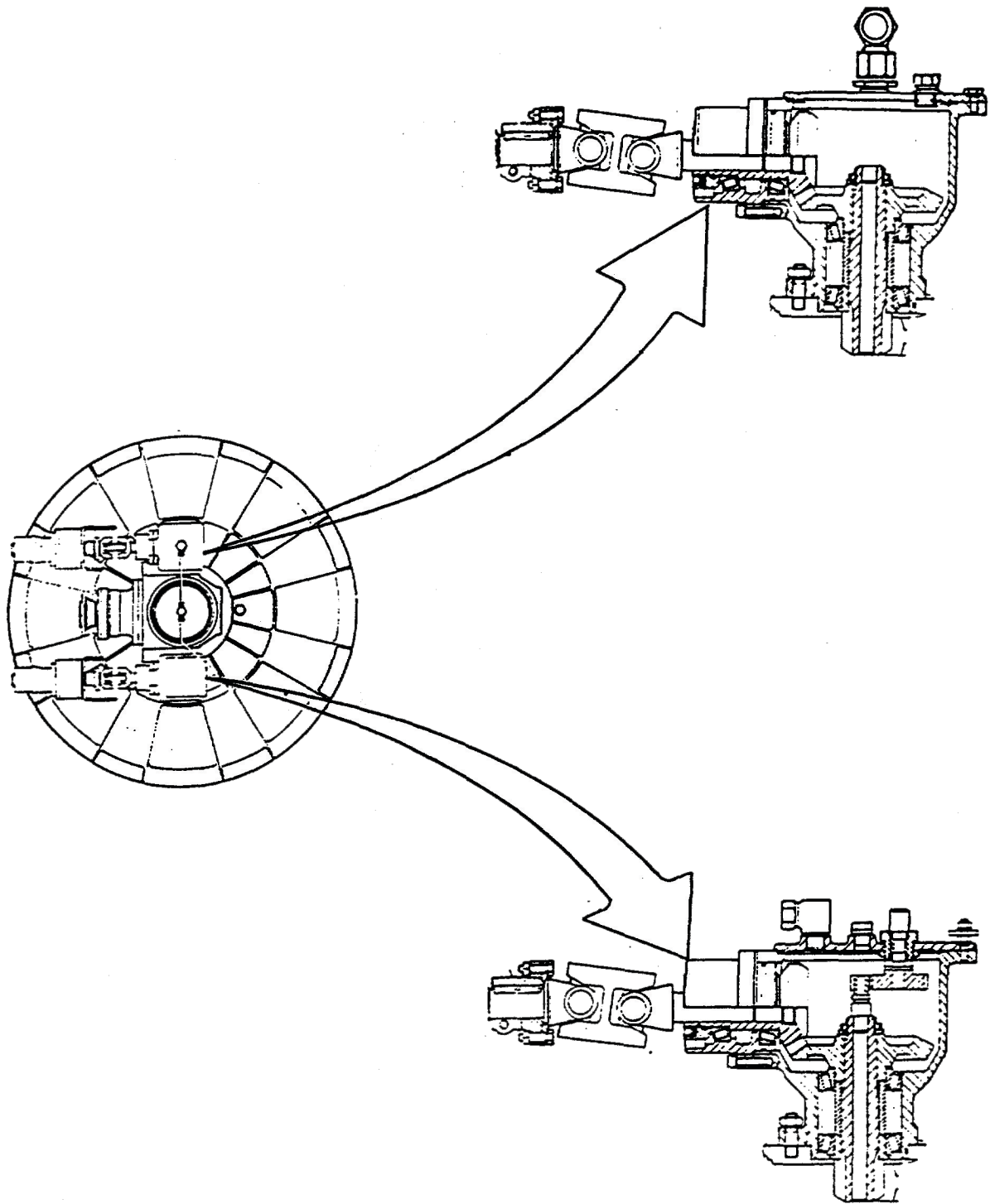

FIGURE 1-10. Steering Gear Assemblies.

i. Lube Oil System. (FIGURE 1-11). A two piece lube oil tank stores the lubricant serving the upper and lower impeller drive enclosures and the right and left steering gear boxes to which it is connected. The lube oil tank is mounted above the Bowthrustrer Assembly or inside the Paint Locker, Inboard Bulkhead when material change is completed. The cover includes an oil inlet, a fill pipe, and mountings and cable connections for the internal float switch. The fill pipe cap includes an air filter. On the front of the tank is an oil level sight glass and the outlet fitting. The lube oil system requires 30 liters to fill the gear enclosures and to fill the reserve tank to the mid point on the sight glass. The outlet fitting near the bottom of the reservoir feeds an oil line going directly to the lower impeller drive enclosure through a fitting on the passage cover. Gravity flow through the line keeps the enclosure flooded at all times. The upper gear enclosure and the right and left steering gear boxes must be filled manually through fill plugs provided for this purpose. All of the lubricated enclosures are vented into a common vent line that returns to the reservoir through a fitting on the cover.

j. Hydraulic Oil Tank. (FIGURE 1-12). The hydraulic oil tank is a 44-liter operating reservoir for the steering gear hydraulic fluid. An oil return line connects to a filter and inlet fitting in one corner of the cover. An adjacent fill pipe is fitted with an air filter cap. A thermometer and sight gauge on the tank side show temperature and level of the tank contents. A low level float switch is mounted in one corner of the tank. Closing the switch activates a remote alarm on the control console when the oil level drops to the set point level. The remaining surface area on the tank cover is used for mounting hydraulic aggregate components. The tank is called the hydraulic aggregate base.

k. Hydraulic Aggregate. (FIGURE 1-13). The hydraulic aggregate is made up of components mounted on top of the hydraulic oil tank. Included are the pressure regulating valve, the valve assembly, the terminal box, the load holding valve, and inter-connecting pipelines, hoses, and wiring which integrate these components with the pump, the oil tank, the steering gear motors, and controls.

l. Hydraulic Pump. (FIGURE 1-14). The pump is driven by a 20-horsepower electric motor. An adapter bolts to the pump housing and to the motor housing and assures alignment of the two keyed shafts. An opening in the adapter provides access to the internal shaft coupling.

m. Pump Motor. (FIGURE 1-14). The 20-horsepower pump motor operates on 220 volt, 60 Hertz, 3 phase ac power.

n. Oil Return Filter. (FIGURE 1-15). The oil return filter is installed on the hydraulic tank cover at the oil return inlet. The return oil flow into the tank is piped first through the filter to remove foreign particles. The replaceable filter element is cleaned periodically.

o. Feedback Unit. (FIGURE 1-16). The feedback unit is housed in a rectangular box mounted above the right steering gear assembly. A shaft protruding through the bottom of the box couples to the shaft protruding through the top of the steering assembly (see FIGURE 1-10). This mechanical link drives internal potentiometers whenever the steering gear is active. Electrical signals from the potentiometers operate local and remote thrust direction indicators. The local indicator is mounted on the box cover. The remote indicator is on the pilot- house control console.

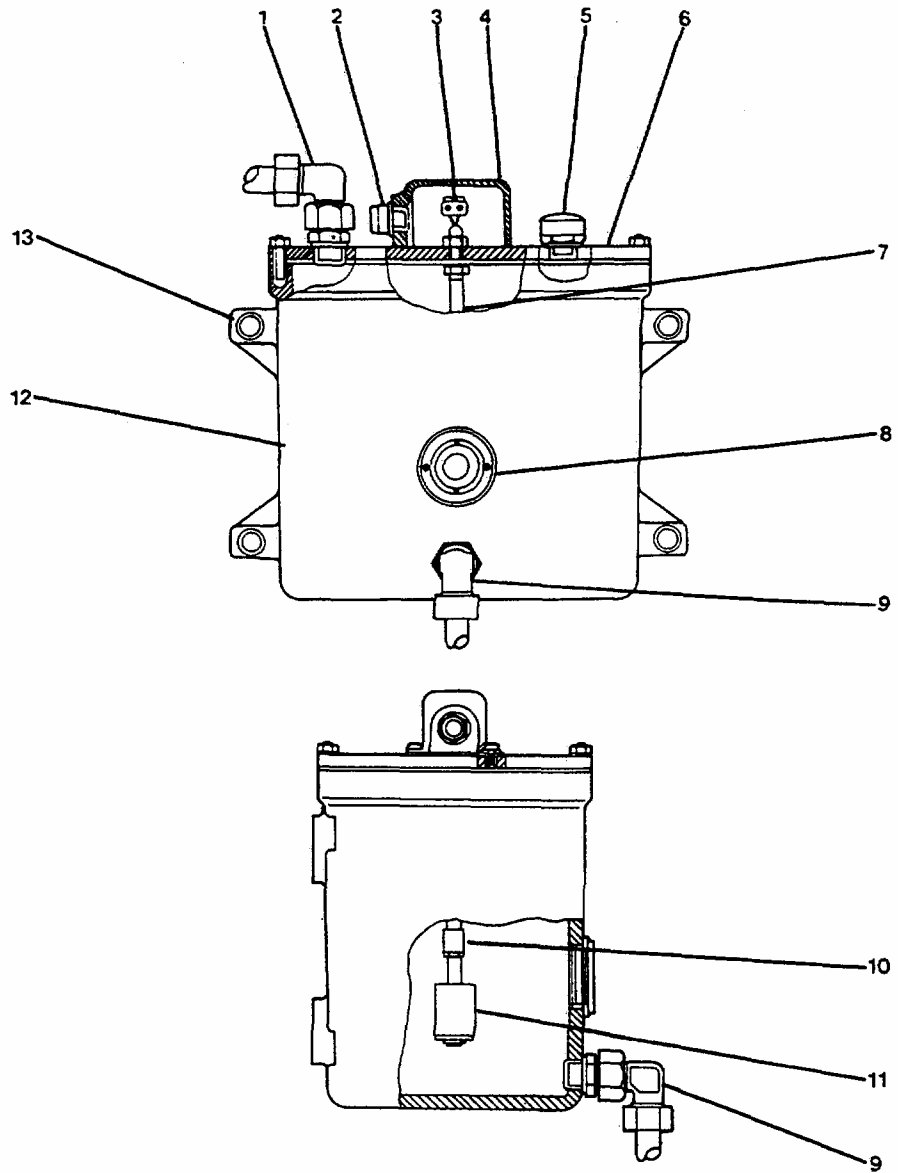

LEGEND

- | | |
|-----------------------------|-------------------|
| 1. OIL INLET FITTING | 8. SIGHT GLASS |
| 2. SCREW-IN CONNECTOR | 9. OUTLET FITTING |
| 3. CABLE CONNECTOR | 10. SLEEVE |
| 4. TANK CAP | 11. FLOAT SWITCH |
| 5. FILL PIPE CAP AND FILTER | 12. TANK BODY |
| 6. COVER | 13. MOUNTING DOGS |
| 7. TANK TUBE | |

FIGURE 1-11. Lube Oil Tank Assembly.

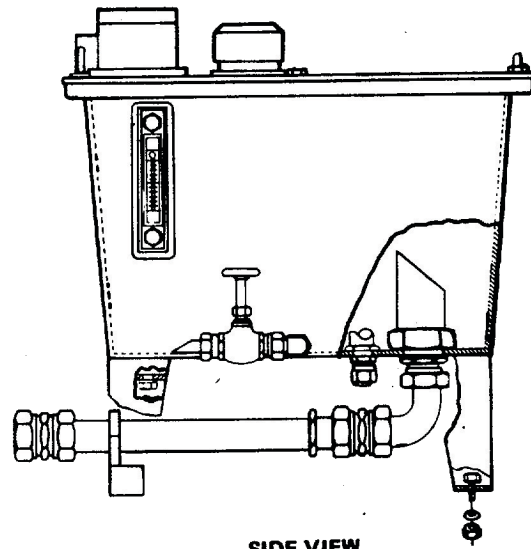

SIDE VIEW

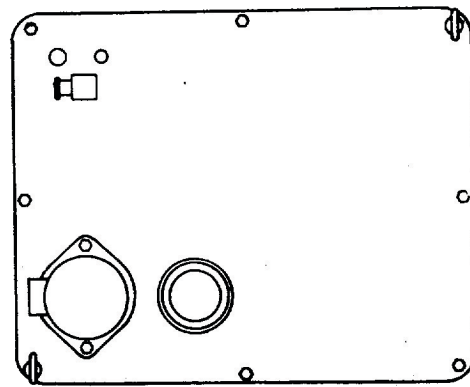

TOP VIEW

FIGURE 1-12. Hydraulic Oil Tank/Aggregate Base.

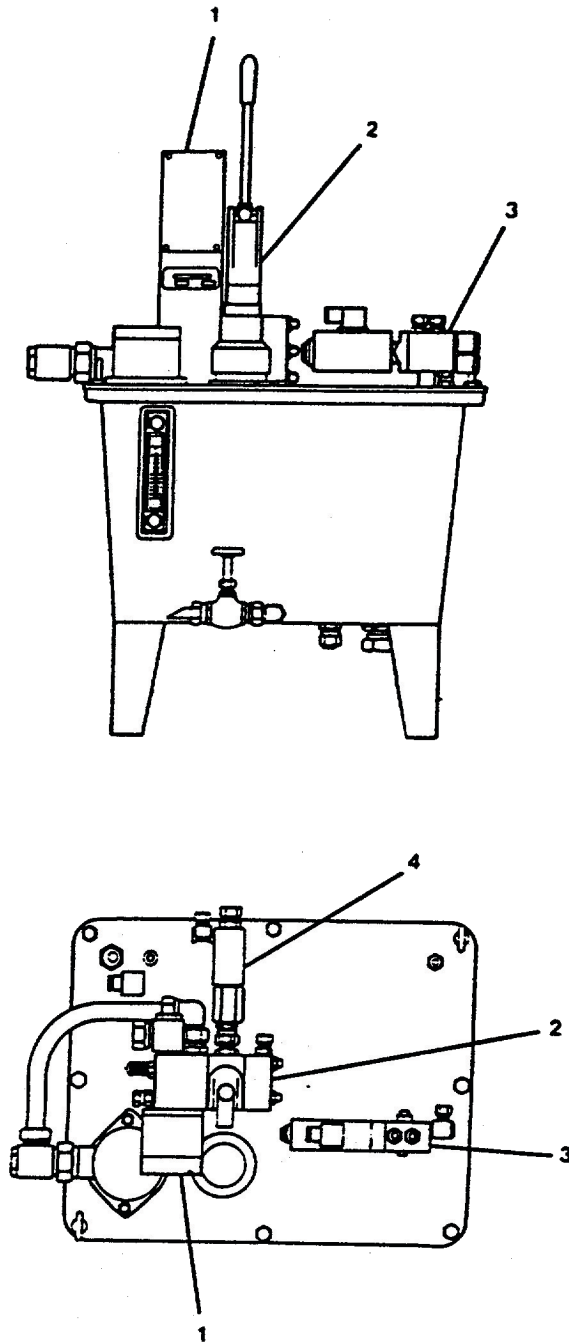

- LEGEND**
- 1. TERMINAL BOX
 - 2. VALVE ASSEMBLY
 - 3. PRESSURE REGULATING VALVE
 - 4. LOAD HOLDING VALVE

FIGURE 1-13. Hydraulic Aggregate.

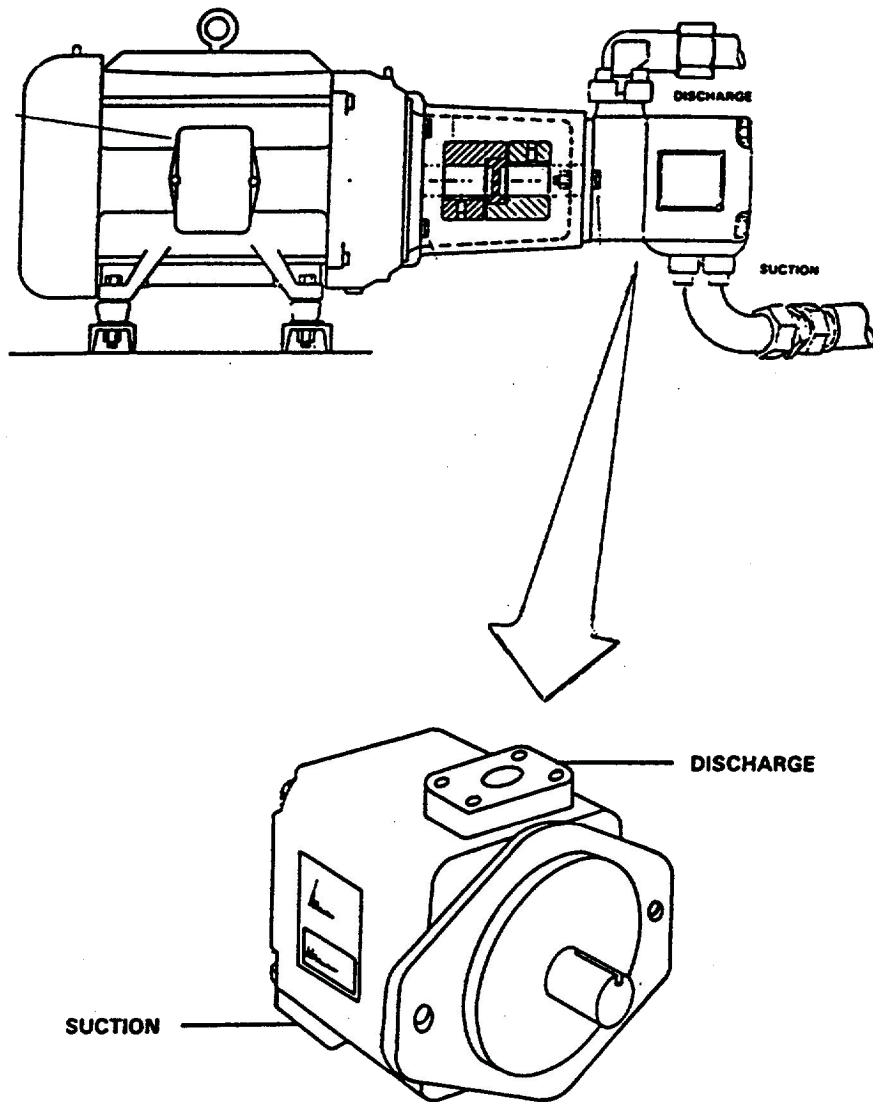
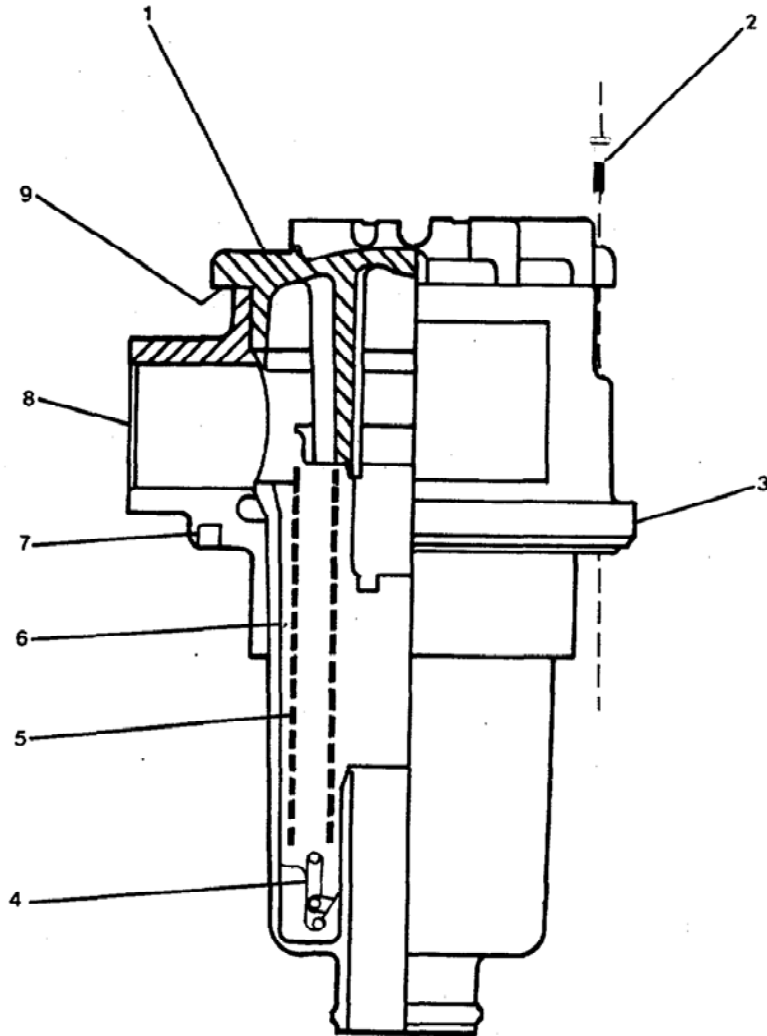

FIGURE 1-14. Hydraulic Pump.



LEGEND

- | | |
|--------------------|----------------------|
| 1. COVER | 6. FILTER POT |
| 2. BOLT (2) | 7. PREFORMED PACKING |
| 3. MOUNTING FLANGE | 8. INLET |
| 4. SPRING | 9. PREFORMED PACKING |
| 5. CARTRIDGE | |

FIGURE 1-15. Oil Return Filter.

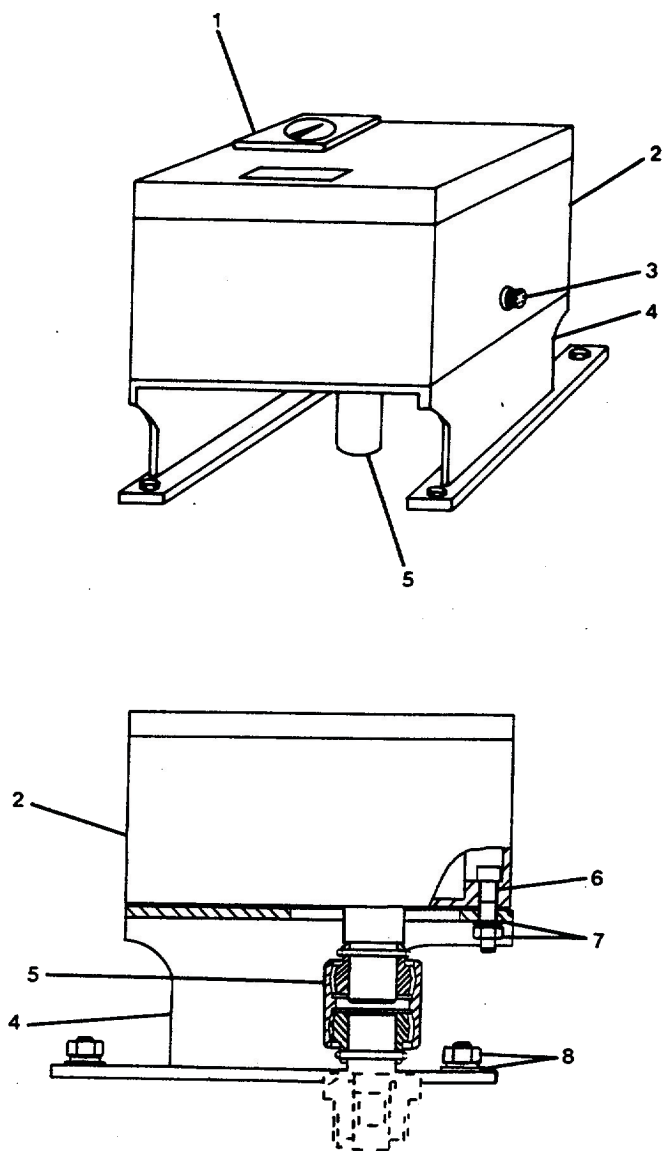

LEGEND

- | | |
|-------------------------------|---------------|
| 1. THRUST DIRECTION INDICATOR | 5. COUPLING |
| 2. RUDDER ANGLE TRANSMITTER | 6. BOLT |
| 3. CABLE CONNECTOR | 7. NUT/WASHER |
| 4. CONSOLE | 8. NUT/WASHER |

FIGURE 1-16. Feedback Unit.

p. Hydraulic Motors. (FIGURE 1-17). Two identical reversible hydraulic motors drive the right and left steering gear assemblies. Piping to the motors is configured to operate both motors in parallel from a common control valve. The motors drive identical gear assemblies which engage opposite arcs of the bevel gear and therefore turn in opposite directions.

q. Disk Brakes. (FIGURE 1-17). A disk brake between each hydraulic motor and the associated steering gear mechanically applies friction to the motor shaft whenever hydraulic pressure is below the threshold of the load holding valve. During normal steering, this brake is disengaged. At all other times, it is engaged.

r. Oil Evacuation Pump. (FIGURE 1-18). This semi-rotary hand pump allows the removal of lube oil and hydraulic fluid from enclosures that cannot be drained by gravity. The pump is bolted to one leg of the framework supporting the motor/pump assembly.

1-9. **Safety, Care and Handling**. Safety precautions must be observed at all times while performing maintenance. General WARNINGS and first-aid data appear in the front of this manual. Review all safety information before starting any task. Carefully read through an entire maintenance procedure before performing any maintenance function. Make sure the task can be done safely. All WARNINGS, CAUTIONS, and NOTES are of great importance to your personal safety and the safety of the equipment.

Section III. PRINCIPLES OF OPERATION

1-10. **General**. The bowthruster waterjet is a propulsion and steering system located at the bow and used in combination with the ship's twin screws and twin rudders to give the LCU added maneuverability. A high volume jet pump driven by the bowthruster diesel engine is the propulsion element. Throttling the engine increases or decreases the thrust force. Twin hydraulic steering motors point the jet nozzle to any desired relative bearing. This controls thrust direction.

Displacement of seawater in a given direction generates an equal recoil force in the opposite direction. This directional recoil force moves the bow of the LCU as needed. Local control of the waterjet is provided in the bowthruster room. A manual control handle on the valve assembly steers the waterjet clockwise or counterclockwise, depending on which way the handle is moved. A thrust direction indicator identical to the one on the pilot house console is mounted on the cover of the rudder angle transmitter. These controls allow a local operator to steer the waterjet on orders from the pilothouse.

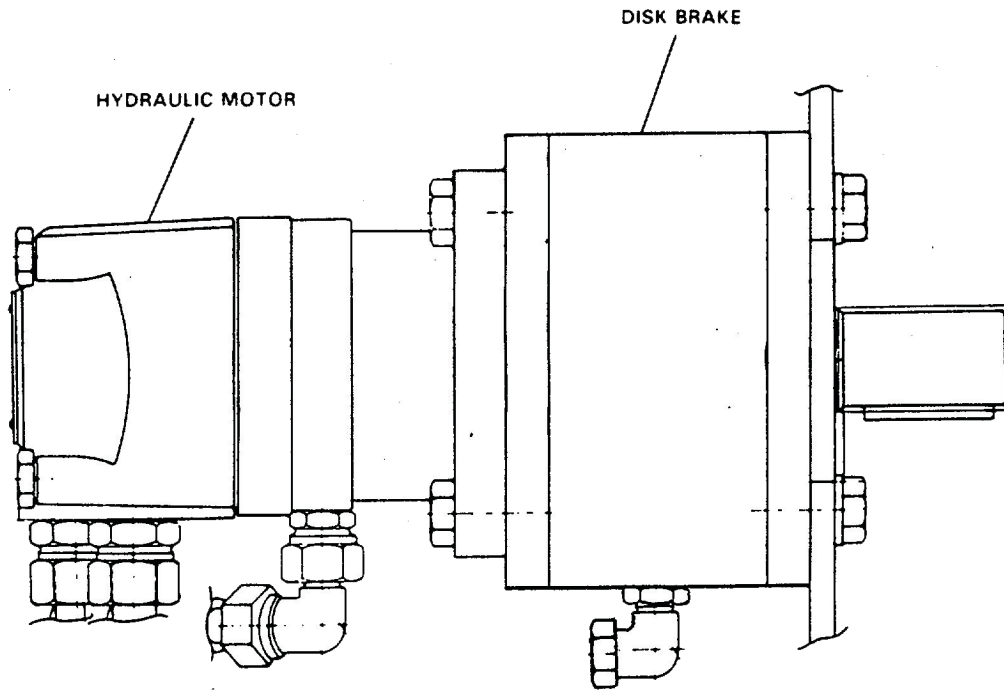

FIGURE 1-17. Hydraulic Motor and Disk Brake Assembly.

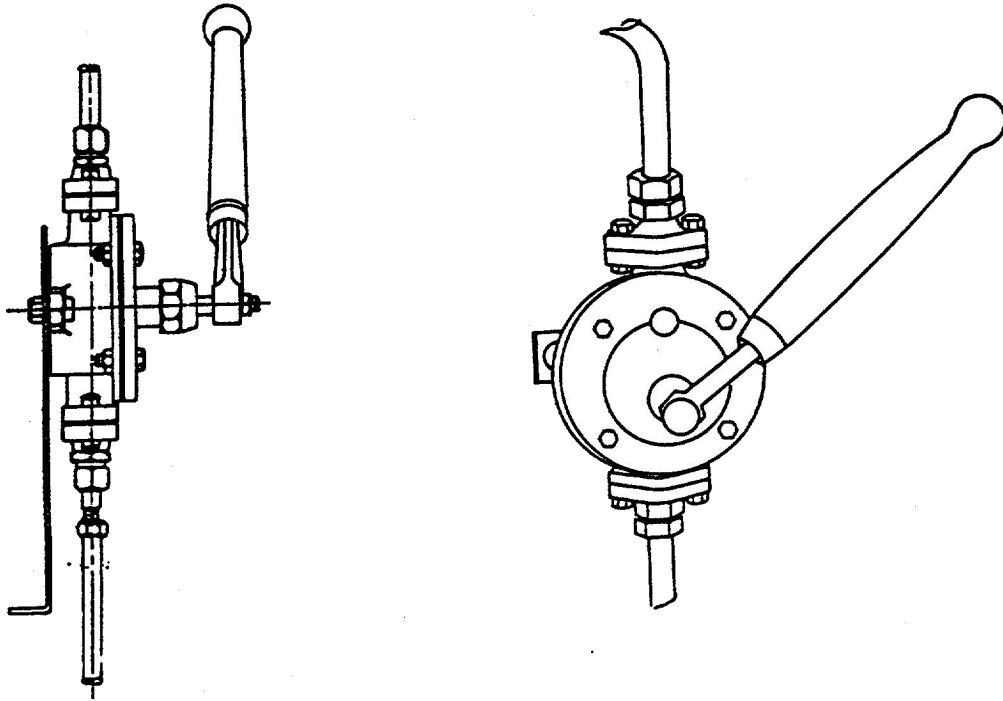

FIGURE 1-18. Oil Evacuation Pump.

CHAPTER 2

UNIT MAINTENANCE INSTRUCTIONS

	Page
Section I. Repair Parts, Special Tools; Test, Measurement, and Diagnostic Equipment (TMDE); and Support Equipment	2-1
Section II. Service Upon Receipt	2-1
Section III. Unit Preventive Maintenance Checks and Services (PMCS)	2-2
Section IV. Unit Maintenance Troubleshooting	2-14
Section V. Unit Maintenance Procedures	2-17
Section VI. Preparation for Storage or Shipment	2-32

Section I. REPAIR PARTS, SPECIAL TOOLS; TEST, MEASUREMENT, AND DIAGNOSTIC EQUIPMENT (TMDE); AND SUPPORT EQUIPMENT

2-1. **Common Tools and Equipment**. For authorized common tools and equipment, refer to the Modified Table of Organization and Equipment (MTOE) applicable to your organization.

2-2. **Special Tools, TMDE, and Support Equipment**. Special tools; test, measurement, and diagnostic equipment; and support equipment requirements are listed and illustrated in the Repair Parts and Special Tools List (RPSTL), TM 55-1905-223-24P. These items are also listed in the Maintenance Allocation Chart (MAC), Appendix B of this manual.

2-3. **Repair Parts**. Repair parts are listed and illustrated in the Repair Parts and Special Tools List (RPSTL), TM 55-1905-223-24P.

Section II. SERVICE UPON RECEIPT

2-4. Checking Unpacked Equipment.

- a. Inspect the equipment for damage incurred during shipment. If the equipment has been damaged, report the damage in accordance with the instructions of DA Pam 738-750.
- b. Check the equipment against the packing slip to see if the shipment is complete. Report all discrepancies in accordance with the instructions of DA Pam 738-750.
- c. Check to see whether the equipment has been modified.
- d. Remove and replace protective caps, plugs, inserts, wrappings, and tape when inspection/inventory is completed. Inspect piping openings for damage. Wipe off dirt, grease, or protective films at time of installation.

- e. Remove chocks from resilient mounted components.
- 2-5. **Initial Setup Procedure.** Includes operational checks and inspections that are not performed for a routine startup.
- 2-6. Normal Startup. Refer to operator's manual, TM 55-1905-223-10.
- 2-7. Shutdown Procedure (Usual or Unusual) Refer to operator's manual, TM 55-1905-223-10.

Section III. UNIT PREVENTIVE MAINTENANCE CHECKS AND SERVICES (PMCS)

2-8. **Explanation of PMCS Table.** PMCS is designed to keep the equipment in good working condition. This is accomplished by performing certain tests, inspections, and services. Table 2-1 lists items to be serviced and the procedures needed to accomplish the PMCS. The "Interval" column tells you when to perform a check or service. If needed, PMCS may be performed more frequently than the indicated interval. The "Procedures" column tells you how to perform the required checks and services. If your equipment does not perform as required, see Table 2-2, Troubleshooting. Report any malfunctions or failures on DA Form 2404. In the Item Number column on DA Form 2404, record the appropriate Item Number from the PMCS table.

TABLE 2-1. PREVENTIVE MAINTENANCE CHECKS AND SERVICES

D - DAILY

M - MONTHLY

Q - QUARTERLY

A - ANNUALLY

AR - AS REQUIRED

ITEM NO.	INTERVAL					ITEM TO BE INSPECTED/SERVICED	PROCEDURE
	D	M	Q	A	AR		
1	•					Lube oil tank	<p>Check / Replenish oil</p> <p>NOTE</p> <p>If oil level is below the window of the gauge glass add oil until the level reaches the midpoint of the window.</p>
2	•					Hydraulic oil tank	<p>Check / Replenish fluid.</p> <p>NOTE</p> <p>The hydraulic system can be operated safely at fluid levels anywhere between the HIGH and LOW marks on the sight gauge/thermometer. The fluid level controls operating temperature. When the level reaches the LOW mark or when fluid temperature exceeds 150° F, add fluid until level reaches HIGH mark.</p>
3			•			Hydraulic oil filter	<p>Clean.</p> <ol style="list-style-type: none"> a. Remove cover bolts. b. Remove cover and preformed packing. c. Remove filter cartridge. d. Plug ends of cartridge.

TABLE 2-1. PREVENTIVE MAINTENANCE CHECKS AND SERVICES

D - DAILY

M - MONTHLY

Q - QUARTERLY

A - ANNUALLY

AR - AS REQUIRED

ITEM NO.	INTERVAL					ITEM TO BE INSPECTED/SERVICED	PROCEDURE
	D	M	Q	A	AR		
3-CONT							<ul style="list-style-type: none"> e. Clean outside with solvent and soft brush. f. Remove one end plug. g. Blow dry from inside outward. h. Remove other end plug. i. Install cartridge. j. Install cover and preformed packing. k. Install cover bolts. l. Operate for leak check.
4			•			Air Filter / Vent Plug Cap (Lube oil tank)	Clean. <ul style="list-style-type: none"> a. Remove cap. b. Immerse in solvent and clean with soft brush. c. Blow dry. d. Install on tank.
5			•			Air Filter Cap (Hyd. Oil Tank)	Clean. <ul style="list-style-type: none"> a. Remove cap. b. Immerse in solvent and clean with soft brush.

TABLE 2-1. PREVENTIVE MAINTENANCE CHECKS AND SERVICES

D - DAILY

M - MONTHLY

Q - QUARTERLY

A - ANNUALLY

AR - AS REQUIRED

ITEM NO.	INTERVAL					ITEM TO BE INSPECTED/SERVICED	PROCEDURE
	D	M	Q	A	AR		
5 - CONT							
6				•		Hydraulic System	<p>c. Blow dry.</p> <p>d. Install on tank.</p> <p>Drain an refill.</p> <p>a. Fit one end of drain hose over thru-way valve outlet and other end in waste oil container.</p> <p>b. Open valve and drain resevoir.</p> <p>c. Dispose of waste oil as directed by supervisor. Close valve.</p> <p>d. Place drain pan under threaded drain plug. Remove plug and drain. Install plug.</p> <p>e. Clean return oil filter (Item 3).</p> <p>f. Clean air filter cap (Item 5).</p> <p>g. Place funnel in filler neck and fill resevoir to HIGH mark on sight gauge/thermometer.</p> <p>h. Wipe spillage. Install air filter cap.</p> <p>i. Operate system while monitoring fluid level.</p>

TABLE 2-1. PREVENTIVE MAINTENANCE CHECKS AND SERVICES

D - DAILY

M - MONTHLY

Q - QUARTERLY

A - ANNUALLY

AR - AS REQUIRED

ITEM NO.	INTERVAL					ITEM TO BE INSPECTED/SERVICED	PROCEDURE
	D	M	Q	A	AR		
6-CONT							during first hour. Replenish as required.
7				•		Lube Oil System	Drain and refill. <ol style="list-style-type: none"> a. Place waste oil container under lube oil drain valve. Open valve. Drain oil. Close valve. b. Remove threaded fill plug in upper gear assembly. c. Insert suction tube of oil evacuation pump into gear case and discharge tube into waste oil container. Pump out oil. d. Remove fill plug from cover of left steering gear box. Insert suction tube of oil evacuation pump. Pump out oil. e. Remove fill plug from cover of right steering gear box. Insert suction tube of oil evacuation pump. Pump out oil. f. Remove oil line into lower gear assembly. Insert suction tube of oil evacuation pump. Pump out oil.

TABLE 2-1. PREVENTIVE MAINTENANCE CHECKS AND SERVICES

D - DAILY

M - MONTHLY

Q - QUARTERLY

A - ANNUALLY

AR - AS REQUIRED

ITEM NO.	INTERVAL					ITEM TO BE INSPECTED/SERVICED	PROCEDURE
	D	M	Q	A	AR		
7-CONT							<p>g. Insert funnel and fill gear box with new oil. Reconnect oil line.</p> <p>h. Insert funnel into fill opening of right gear box. Fill with oil. Install plug.</p> <p>i. Insert funnel into fill opening of left gear box. Fill with oil. Install plug.</p> <p>j. Insert funnel into fill opening of upper gear assembly. Fill with oil. Remove funnel, wipe spillage, install plug.</p> <p>k. Remove air filter, filler cap from cover of oil tank.</p> <p>l. Insert funnel into fill opening and fill tank to midpoint on oil gauge glass.</p> <p>m. Remove funnel, wipe spillage.</p> <p>n. Clean air filter (Item 4) and install.</p> <p>o. Operate system while monitoring oil level tank. Replenish as required.</p>

TABLE 2-1. PREVENTIVE MAINTENANCE CHECKS AND SERVICES

D - DAILY

M - MONTHLY

Q - QUARTERLY

A - ANNUALLY

AR - AS REQUIRED

ITEM NO.	INTERVAL					ITEM TO BE INSPECTED/SERVICED	PROCEDURE
	D	M	Q	A	AR		
8				•		Electric Pump Motor	Lubricate. <ul style="list-style-type: none"> a. Wipe grease fitting. b. While motor is stationary inject 2 or 3 strokes of lithium base bearing grease. c. Repeat for grease fitting at opposite end of shaft. d. Wipe off excess.
9	•		•			Drive Shaft	Check that the flanges (both ends) are connected securely to the engine and waterjet. Check for excess dirt around U-joints. Service. <ul style="list-style-type: none"> a. Locate the grease fitting on the spline. b. Wipe old grease and dirt from fitting with a rag. c. Using a grease gun, apply lithium base bearing grease to the fitting until it will take no more or until grease seeps out.

TABLE 2-1. PREVENTIVE MAINTENANCE CHECKS AND SERVICES

D - DAILY

M - MONTHLY

Q - QUARTERLY

A - ANNUALLY

AR - AS REQUIRED

ITEM NO.	INTERVAL					ITEM TO BE INSPECTED/SERVED	PROCEDURE
	D	M	Q	A	AR		
9-CONT							<p>d. Clean the grease fittings on each U-joint.</p> <p>e. Apply grease to fittings as in step c above.</p> <p>f. Wipe away excess grease with a rag to prevent excessive dirt buildup.</p>
10		•				Hydraulic Aggregate Base	<p>Check piping connections for leaks.</p> <p>Check for loose bolts, nuts, and screws.</p> <p>Check for broken thermometer and sight gauge.</p>
11	•	•				Oil Return Filter Assembly	<p>Check that mounting bolts are secure.</p> <p>Check that cover is hand tight.</p> <p>Check that oil return line is secure.</p> <p>Check for leakage around return oil line.</p>
12		•			•	Steering Gear Assemblies, Left and Right	<p>Check that mounting is secure.</p> <p>Check that connection is secure.</p> <p>Fill gearbox.</p>

TABLE 2-1. PREVENTIVE MAINTENANCE CHECKS AND SERVICES

D - DAILY

M - MONTHLY

Q - QUARTERLY

A - ANNUALLY

AR - AS REQUIRED

ITEM NO.	INTERVAL					ITEM TO BE INSPECTED/SERVICED	PROCEDURE
	D	M	Q	A	AR		
12-CONT							<ul style="list-style-type: none"> a. Remove threaded fill plug cover. b. Insert funnel and fill gearbox with oil. c. Install threaded fill plug. d. Wipe up spillage with rags.
13		•				Hydraulic Motor	<ul style="list-style-type: none"> Check that mounting is secure. Check that all connections are secure.
14		•				Pump Assembly	<ul style="list-style-type: none"> Inspect discharge connection and coupling for secureness. Inspect suction connection and coupling for secureness. Inspect motor mounting bolts for secureness.
15	•					Oil Tank Assembly	<ul style="list-style-type: none"> Inspect for fluid leaks. Fill oil tank. a. Place funnel into fill opening and fill tank to midpoint of oil gauge glass. b. Remove funnel and wipe spillage.

TABLE 2-1. PREVENTIVE MAINTENANCE CHECKS AND SERVICES

D - DAILY

M - MONTHLY

Q - QUARTERLY

A - ANNUALLY

AR - AS REQUIRED

ITEM NO.	INTERVAL					ITEM TO BE INSPECTED/SERVICED	PROCEDURE
	D	M	Q	A	AR		
15-CONT							<p>c. Install vent plug.</p> <p>d. Operate system for leak check.</p> <p>e. Monitor oil during 15 minute run and replenish as required.</p> <p>Inspect all connections for secureness.</p>
16		•				Hydraulic Aggregate	<p>Check terminal box connections and mounting.</p> <p>Check valve assembly for loose screws and nuts.</p> <p>Check regulating valve connections and mounting.</p> <p>Check holding valve connections and mounting.</p>
17		•				Disk Brake	<p>Check that mounting and connections are secure.</p>
18		•				Upper Gear Assembly	<p>Check that mounting is secure.</p> <p>Check that the vertical shaft is securely seated.</p>

TABLE 2-1. PREVENTIVE MAINTENANCE CHECKS AND SERVICES

D - DAILY

M - MONTHLY

Q - QUARTERLY

A - ANNUALLY

AR - AS REQUIRED

ITEM NO.	INTERVAL					ITEM TO BE INSPECTED/SERVICED	PROCEDURE
	D	M	Q	A	AR		
18-CONT	•						<p>Check the oil level.</p> <p>Fill oil.</p> <ol style="list-style-type: none"> a. Remove oil fill plug. b. Insert funnel. c. Add oil until the level reaches the fill opening. d. Replace the oil fill plug. e. Wipe up spillage.
19		•				Oil Evacuation Pump	<p>Check that mounting is secure.</p> <p>Check that exterior bolts and nuts are secure.</p> <p>Check that suction and discharge connections are secure.</p> <p>Check that handle operates freely.</p> <p>Prime pump. Disconnect the suction tube at the pump union.</p>

TABLE 2-1. PREVENTIVE MAINTENANCE CHECKS AND SERVICES

D - DAILY

M - MONTHLY

Q - QUARTERLY

A - ANNUALLY

AR - AS REQUIRED

ITEM NO.	INTERVAL					ITEM TO BE INSPECTED/SERVICED	PROCEDURE
	D	M	Q	A	AR		
20		• •			•	Waterjet Assembly	<p>Check that mounting is secure.</p> <p>Check that exterior bolts, nuts, and screws are secure.</p> <p>Service.</p> <p>a. Clean cover.</p> <p>b. Add two drops of oil around the adjusting</p>

Section IV. UNIT MAINTENANCE TROUBLESHOOTING

2-9. Troubleshooting. Both a symptom index and a troubleshooting table are provided. The symptom index will help you locate the information you need for troubleshooting.

SYMPTOM INDEX		Troubleshooting Procedure (Table 2-2)
BOWTHRUSTER		
Not operating		Item 1
Not steerable		Item 2
SIGHT GAUGE/THERMOMETER		
Reading exceeds 150°F		Item 3
VIBRATION/NOISE		
Excessive		Item 4
HYDRAULIC OIL		
Frothy		Item 5

Table 2-2 lists the common fault conditions that may be found during operation or maintenance of the equipment. Look for causes and do corrective actions in the order listed. This manual cannot list every symptom that may show up, and it cannot list all the possible causes and corrective actions. If a symptom is not listed, or if it keeps up after you have performed the corrective actions, notify your supervisor.

Table 2-2. Troubleshooting

Malfunction	
Test or Inspection	
Corrective Action	

1. Bowthruster not operating.

STEP 1. Check bowthruster engine operating and driveshaft engaged and turning.
Refer to TM 55-1905-223-24-5 for starting procedures.

- STEP 2. Check power to Pilothouse Control panel.
- a. Check circuit breaker ON at EP 102.
 - b. Refer to TM 55-1905-223-24-18 for repair of Control Panel.

2. Bowthruster operating - not steerable.

STEP 1. Check air pressure to Control Panel.
Refer to TM 55-1905-223-24-18 for repair of Control Panel.

Table 2-2. Troubleshooting - CONT

Malfunction	Test or Inspection	Corrective Action
	STEP 2.	Check electric motor at bowthruster is operating by visually verifying rotation of jaw coupling. Check circuit breaker at EP.
	STEP 3.	Check sight gauges for low hydraulic fluid. Check piping connections and hoses for leaks and cracks. No leaks found - add fluid (Table 2-1, Item 2).
	STEP 4.	Visually verify point of rudder transmitter at bowthruster is pointed directly aft. Assure proper alignment by rotating bowthruster toward forward while applying foot pressure to adjustment device until adjustment device seats into the mounting flange. Remove four screws holding the plexiglass cover atop the potentiometer. Adjust pointer toward aft by loosening the three screws holding the potentiometer locking ring. Turn potentiometer by hand until the pointer opposite the direction of thrust (aft). Tighten three screws holding the potentiometer locking ring. Replace plexiglass cover and tighten screws.
3.	Sight Gauge/Thermometer reading exceeds 150°F	
	STEP 1.	Check fluid level for LOW reading. Add fluid to bring level to HIGH mark (Table 2-1, Item 2).
	STEP 2.	Check by feeling Hydraulic vane pump, HY-motors, and brakes for excessive temperature.
4.	Vibration/Noise Excessive	
		Check for loose mounting bolts. Tighten mounting bolts. Refer to appropriate paragraph in this manual for correct torque.
5.	Hydraulic oil is frothy.	
	STEP 1.	Check for clogged air filter on oil tank. Clean filter (Table 2-1, Item 5).
	STEP 2.	Check for low oil level. Add oil (Table 2-1, Item 2).

Table 2-2. Troubleshooting - CONT

Malfunction	Test or Inspection	Corrective Action
	STEP 3.	Check for overheated oil. Change oil (Table 2-1, Item 6).
	STEP 4.	Check for air in the oil. a. Check/secure piping connections. b. Check hoses for cracks. c. Change oil (Table 2-1, Item 6).

Section V. UNIT MAINTENANCE PROCEDURES

MAINTENANCE OF BOWTHRUSTER WATERJET

2-10. Repair/Replace Oil Tank Assembly. (FIGURE 2-1)

This task covers: a. Removal, b. Repair, c. Replacement.

INITIAL SETUPTools

Tool kit, general mechanic's,
5180-00-699-5273
Combination wrench set, metric, 10mm
through 24mm 5120-01-046-4979
Socket set, Socket wrench, ½" drive, 10mm through
27mm 5120-01-429-3675

Equipment Condition

TM 55-1905-223-10, bowthruster waterjet shutdown
and bowthruster steering pump motor controller
power OFF at breaker. Tag "Out of Service - Do
Not Operate" (FM 55-502).

Materials/Parts

Preformed packing P/N 1002210
Vent plug P/N 1009813
Oil tank assembly P/N 1048050
Warning tags, Item 5, Appendix C
Utility pail, Item 6, Appendix C
Wiping rag, Item 1, Appendix C

REMOVAL (FIGURE 2-1)WARNING

Use extreme caution when checking energized circuits to avoid electrocution. Always ensure affected circuits have been secured, locked out and tagged out. Performing maintenance with circuits energized may result in death or injury to personnel or equipment damage.

- a. Place utility pail under drain valve (9).
- b. Remove fill cap and filter (5).
- c. Open drain valve (9) and drain oil into utility pail.
- d. Dispose of waste oil as directed by supervisor.
- e. Close drain valve (9). Wipe up spillage.
- f. Replace fill cap and filter (5).
- g. Disconnect oil inlet fitting (1) from tank assembly. Plug opening.
- h. Disconnect outlet fitting (7) from tank assembly. Plug opening.

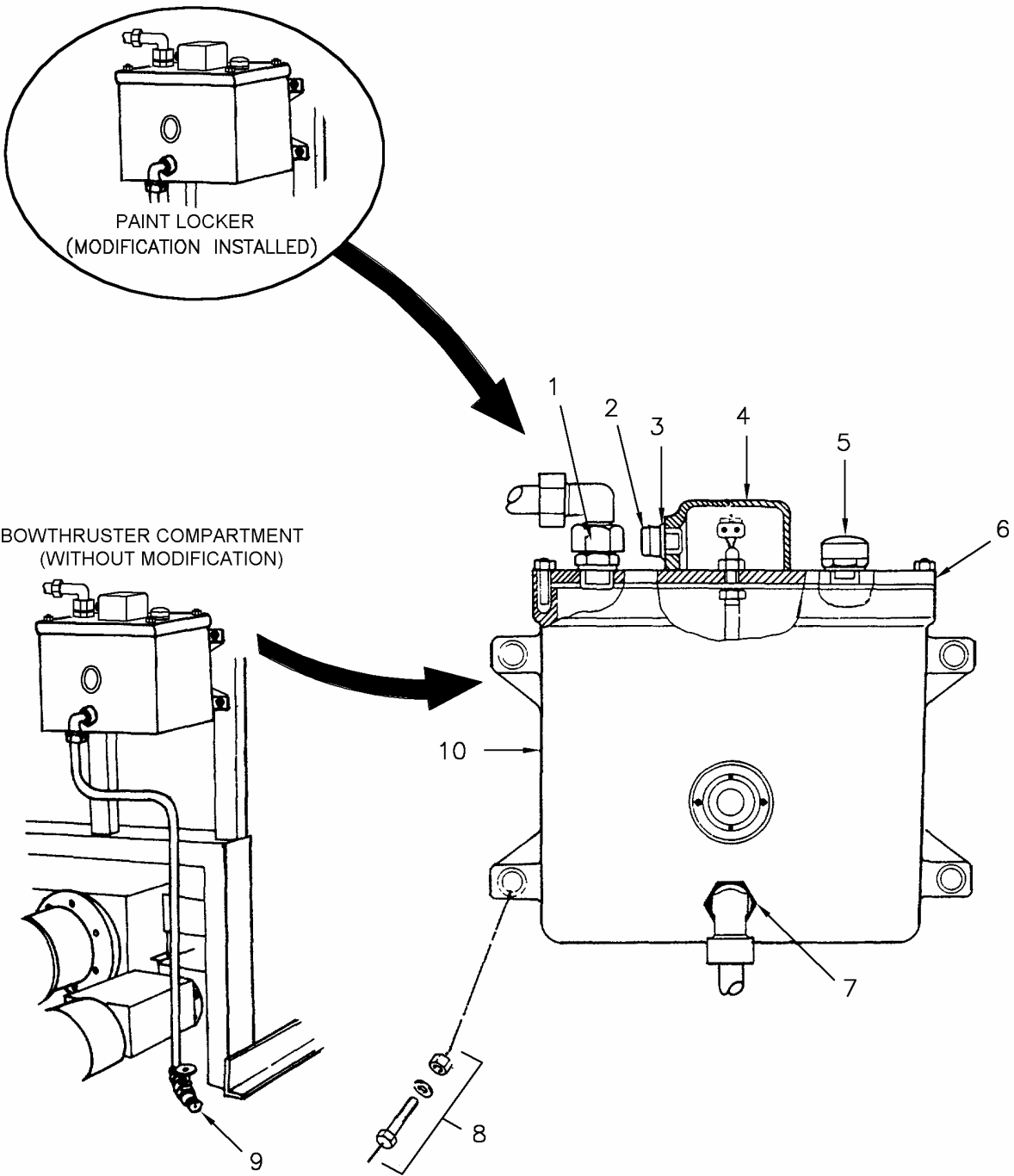

- | | |
|------------------------|----------------------------|
| 1. OIL INLET FITTING | 6. TANK COVER |
| 2. SCREW-IN CONNECTOR | 7. OUTLET FITTING |
| 3. PREFORMED PACKING | 8. BOLTS, NUTS AND WASHERS |
| 4. FILTER OPENING CAP | 9. DRAIN VALVE |
| 5. FILL CAP AND FILTER | 10. TANK ASSEMBLY |

FIGURE 2-1. Lube Oil Tank Assembly.

- i. Remove four bolts, nuts, and washers (8) securing oil tank assembly (10) to frame.
- j. Remove oil tank assembly (10).

REPAIR (FIGURE 2-1)

- a. Remove screw-in connector (2) and preformed packing (3) from filter opening cap (4). Discard preformed packing (3).
- b. Install new preformed packing (3) with screw-in connector (2) into filter opening cap (4).
- c. Clean fill cap and filter (5), refer to PMCS, Item 4. Check for cracks, dents or broken seals. Replace if required.
- d. Install fill cap and filter (5) into tank cover (6).

REPLACEMENT (FIGURE 2-1)

- a. Position tank (10) on frame and secure with four bolts, nuts, and washers (8). Torque to 15 ft-lbs.
- b. Remove plugs from inlet and outlet lines.
- c. Connect outlet fitting (7) to tank assembly (10).
- d. Connect oil inlet fitting (1) to tank assembly (10).
- e. Remove fill cap and filter (5).
- f. Fill with lube oil to appropriate level in sight glass, refer to PMCS, Item 1.
- g. Install fill cap and filter (5).
- h. Restore power to the assembly and remove warning tags.

2-11. Repair/Replace Oil Return Filter Assembly. (FIGURE 2-2)

This task covers: a. Removal, b. Repair/Service, c. Replacement.

INITIAL SETUP

Tools

Tool kit, general mechanic's,
5180-00-699-5273
Combination wrench set, metric, 10mm
through 24mm 5120-01-046-4979

Equipment Condition

TM 55-1905-223-10, bowthruster waterjet shutdown
and tagged "Out of Service - Do Not Operate"
(FM 55-502).

Materials/Parts

Return oil filter assembly P/N 6730162286
Preformed packing P/N 2307632101
Preformed packing P/N 0040141463
Preformed packing P/N 2307032151
Filter cartridge P/N H68/1
Soft brush, Item 3, Appendix C
Cleaning pan, Item 4, Appendix C
Wiping rags, Item 1, Appendix C
Solvent, Item 2, Appendix C
Warning tags, Item 5, Appendix C

REMOVAL

WARNING

Use extreme caution when checking energized circuits to avoid electrocution. Always ensure affected circuits have been secured, locked out and tagged out. Performing maintenance with circuits energized may result in death or injury to personnel or equipment damage.

- a. Rotate access cover (2) counterclockwise by hand pressure on protruding fins.
- b. Remove access cover (2) and preformed packing (1).
- c. Remove filter cartridge (6).
- d. Unscrew oil return inlet line (10). Plug open line.
- e. Remove filterpot (7) and preformed packing (9).
- f. Remove bolts (3) from mounting flange (5).
- g. Remove filter assembly (4) and preformed packing (8).

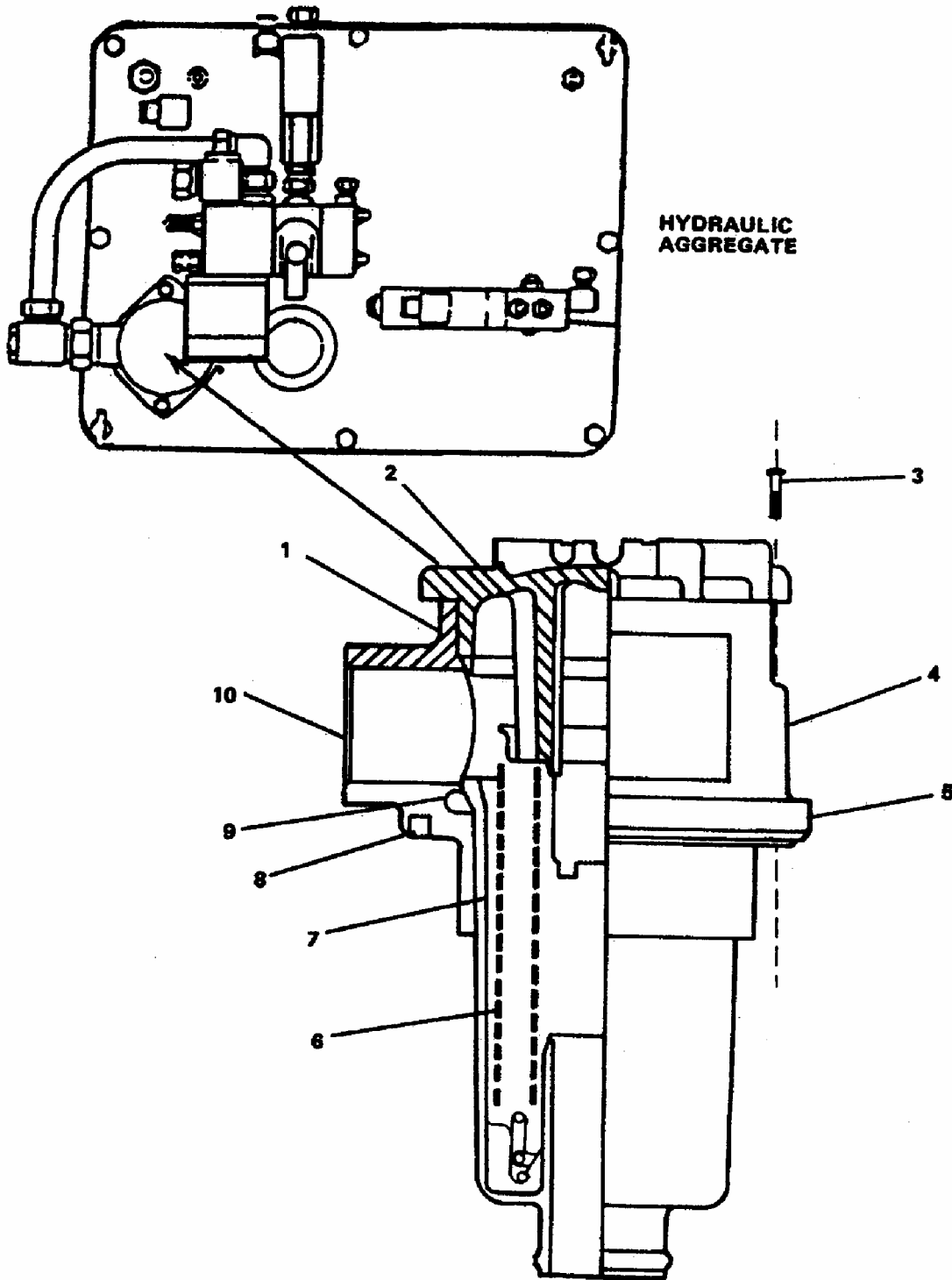

FIGURE 2-1. Lube Oil Tank Assembly.

REPAIR/SERVICE

- a. Repair of hydraulic aggregate consists of Replacement/Repair of the filter assembly.
- b. Using solvent and soft brush, clean the filterpot (7), cover (2), and mounting bolts (3).
- c. Wipe dry.
- d. Inspect all parts. Replace items showing thread damage, flange defects, cracks, corrosion, deformation, or unserviceability.
- e. Plug ends of cartridge (6).
- f. Brush outside with solvent.
- g. Remove end plugs.

REPLACEMENT

- a. Install filter cartridge (6) into filterpot (7).
- b. Install preformed packing (9) on upper flange of filterpot (7) and install into filter assembly (4),
- c. Install cover (2) and preformed packing (1).
- d. Wipe mounting surface clean.
- e. Install preformed packing (8) on flange of filter assembly (4) and insert into mounting hole.
- f. Install mounting bolts (3) in the mounting flange (5).
- g. Unplug and connect return flow oil line (10) to the filter assembly. (4).
- h. Restore power and remove warning tag.
- i. Operate bowthruster and check for leaks.

2-12. Repair Feedback Unit. (FIGURE 2-3)

This task covers: a. Disassembly, b. Repair, c. Assembly.

INITIAL SETUP

Tools

Tool kit, general mechanic's,
5180-00-699-5273
Combination wrench set, metric, 10mm
through 24mm 5120-01-046-4979
Torque wrench kit,
P/N 3377216

Equipment Condition

TM 55-1905-223-10, bowthruster waterjet shutdown
and tagged "Out of Service - Do Not Operate"
(FM 55-502).

Materials/Parts

Rudder angle transmitter
P/N 1053070
Warning tags, Item 5, Appendix C
Electrical tape, Item 7, Appendix C

DISASSEMBLY

WARNING

Use extreme caution when checking energized circuits to avoid electrocution. Always ensure affected circuits have been secured, locked out and tagged out. Performing maintenance with circuits energized may result in death or injury to personnel or equipment damage.

- a. Remove screws and washers (1) and remove top cover (2).
- b. Tag and remove electrical wires from the terminal block located inside the rudder angle transmitter (9).
- c. Loosen the screws on cable clamp (3) and pull the electrical wires from the rudder angle transmitter (9).
- d. Remove plain hexagon nuts (7), spring washers (6) and hexagon head cap screws (5), holding the rudder angle transmitter (9) to the console (4).
- e. Remove the rudder angle transmitter (9) by lifting upward until the drive coupling (8) clears the console (4).

NOTE

If the rudder angle transmitter (9) is to be reinstalled, do not rotate the drive coupling (8) or the transmitter reading will change.

REPAIR

Repair at this level is limited to replacement of rudder angle transmitter (9).

ASSEMBLY

- a. Guide the drive coupling (8) into the console (4) until the mounting holes on the console (4) align with the mounting holes on the rudder angle transmitter (9).
- b. Install the hexagon head cap screws (5), spring washers (6), and plain hexagon nuts (7). Torque to 15 ft-lbs.
- c. Insert the electrical wires through the cable clamp (3) and into the terminal block inside the rudder angle transmitter (9). Tighten the screws on the cable clamp (3).
- d. Tighten the screws on the terminal block using a jewelers screwdriver and remove the tags from the electrical wires.
- e. Install the top cover (2) and secure with screws and washers (1).
- f. Restore bowthruster waterjet to operation and remove warning tag.
- g. Check the transmitter alignment. Refer to Troubleshooting, Table 2-2, Item 2, Step 4.

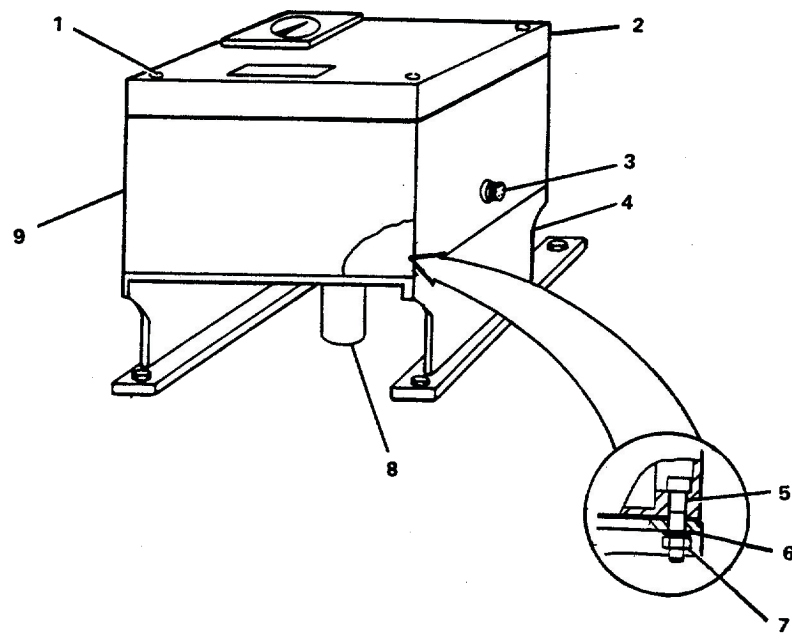

FIGURE 2-3. Feedback Unit.

2-13. Repair/Replace Oil Evacuation Pump. (FIGURE 2-4)

This task covers: a. Removal, b. Repair, c. Replacement.

INITIAL SETUPTools

Tool kit, general mechanic's,
5180-00-699-5273
Combination wrench set, metric, 10mm thru 24mm,
5120-01-046-4979
Torque wrench kit, P/N 3377216

Equipment Condition

Normal operation.

Materials/Parts

Oil evacuation pump P/N 1009004E1

REMOVAL

- a. Remove the hexagon capscrews (2), hexagon plain nuts (3), and spring tension washers (4) holding the oil evacuation pump (1) to the mounting bracket (5).
- b. Remove the oil evacuation pump (1).

REPAIR

Repair is by replacement of oil evacuation pump (1).

REPLACEMENT

- a. Install the oil evacuation pump (1) on mounting bracket (5).
- b. Align the pump mountings dogs over the holes in the mounting bracket (5).
- c. Install hexagon head capscrews (2), spring tension washers (4), and hexagon plain nuts (3). Torque to 29 ft-lbs.

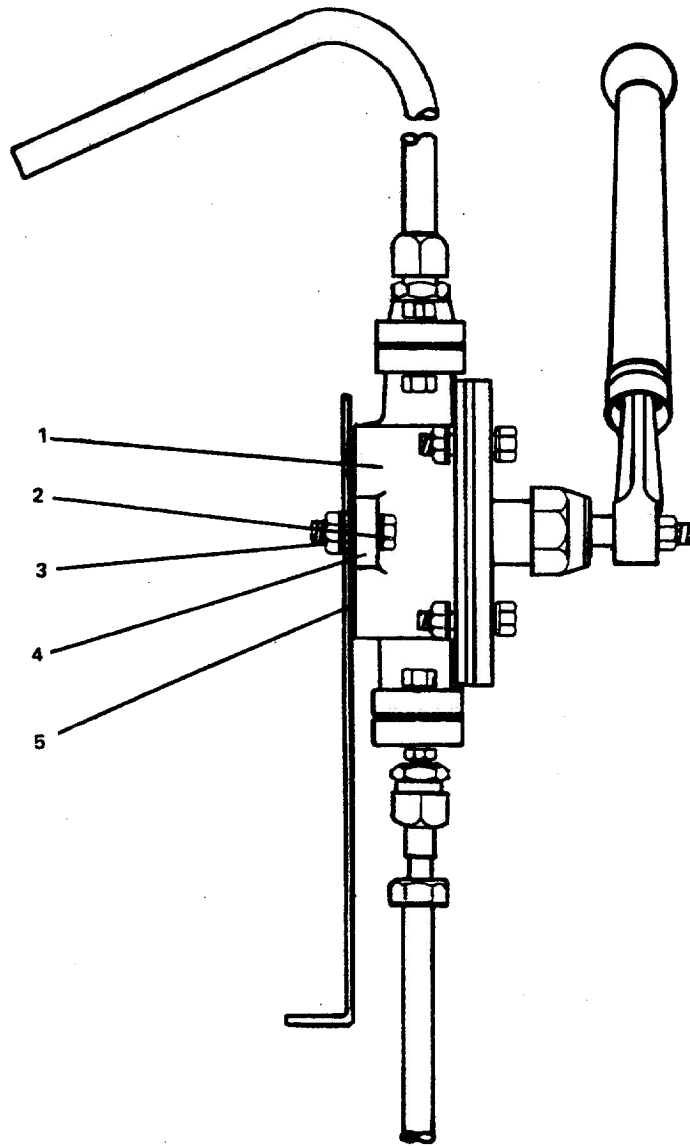

FIGURE 2-4. Oil Evacuation Pump.

2-14. Repair/Replace Drive Shaft. (FIGURE 2-5)

This task covers: a. Removal, b. Disassembly, c. Repair, d. Assembly,
e. Replacement

INITIAL SETUP

Tools

Tool kit, general mechanic's,
5180-00-699-5273
Combination wrench set, metric, 10mm
through 24mm 5120-01-046-4979
Torque wrench kit,
P/N 3377216

Equipment Condition

TM 55-1905-223-10, bowthruster engine and
bowthruster waterjet shutdown and tagged
"Out of Service - Do Not Operate" (FM 55-502).
Fenders or gratings removed as needed for access.

Materials/Parts

Drive shaft P/N 287.00.O.05
Warning tags, Item 5, Appendix C
Solvent, Item 2, Appendix C
Rags, Item 1, Appendix C

REMOVAL

WARNING

Use extreme caution when checking energized circuits to avoid electrocution. Always ensure affected circuits have been secured, locked out and tagged out. Performing maintenance with circuits energized may result in death or injury to personnel or equipment damage.

- a. On the aft end of the drive shaft (5), remove eight bolts (1), lockwashers (2), and nuts (3) joining flange yoke (4) to engine coupling flange (20).
- b. On the forward end of the drive shaft (5), remove eight bolts (8), lockwashers (7) and nuts (6) joining flange yoke (9) to waterjet drive flange (10).
- c. Compress spline (15) to achieve required clearance for drive shaft removal.
- d. Remove drive shaft (5).

DISASSEMBLY

- a. Remove two retaining rings (13) from the shaft yoke (11).
- b. Remove both bearing caps (12) out of the flange yoke (9).
- c. Remove both bearing caps out of the shaft yoke (11) and remove the flange yoke (9) from the shaft yoke (11).

- d. Remove the bearing assembly cross (14).
- e. At the other end of the drive shaft, remove two retaining rings (17) from the shaft yoke (19).
- f. Remove both bearing caps (18) out of the flange yoke (4).
- g. Remove both bearing caps out of the shaft yoke (19) and remove the flange yoke.
- h. Remove the bearing assembly cross (16).

REPAIR

- a. Using solvent, clean all parts and wipe dry.
- b. Replace all parts showing deformation, corrosion, or other signs of unserviceability.

ASSEMBLY

- a. Install the bearing assembly cross (16) into the flange yoke (4).
- b. Install flange yoke (4) into shaft yoke (19) and install bearing caps.
- c. Install retaining rings (17).
- d. Install bearing caps (18) on flange yoke (4) and install retaining rings (17).
- e. Install the bearing assembly cross (14) into the flange yoke (9).
- f. Install flange yoke (9) into shaft yoke (11).
- g. Install bearing caps (12) on flange yoke (9) and install retaining rings (13).

REPLACEMENT

- a. Position drive shaft (5) between engine and bowthruster waterjet.
- b. Align the forward end of the drive shaft (5) with the waterjet flange (10). Secure flange yoke (9) to waterjet flange (10) with eight bolts (8), lockwashers (7), and nuts (6). Torque nuts (6) alternately to 48 ft-lb.

- c. Align the aft end of the drive shaft (5) with the engine coupling flange (20). Secure flange yoke (4) to engine coupling flange (20) with eight bolts (1), lockwashers (2), and nuts (3). Torque nuts (3) alternately to 48 ft-lb.
- d. Install fenders or gratings removed for access.
- e. Service using procedure in Table 2-1, Item 9.
- f. Remove warning tags and return bowthruster waterjet and bowthruster engine to operation.

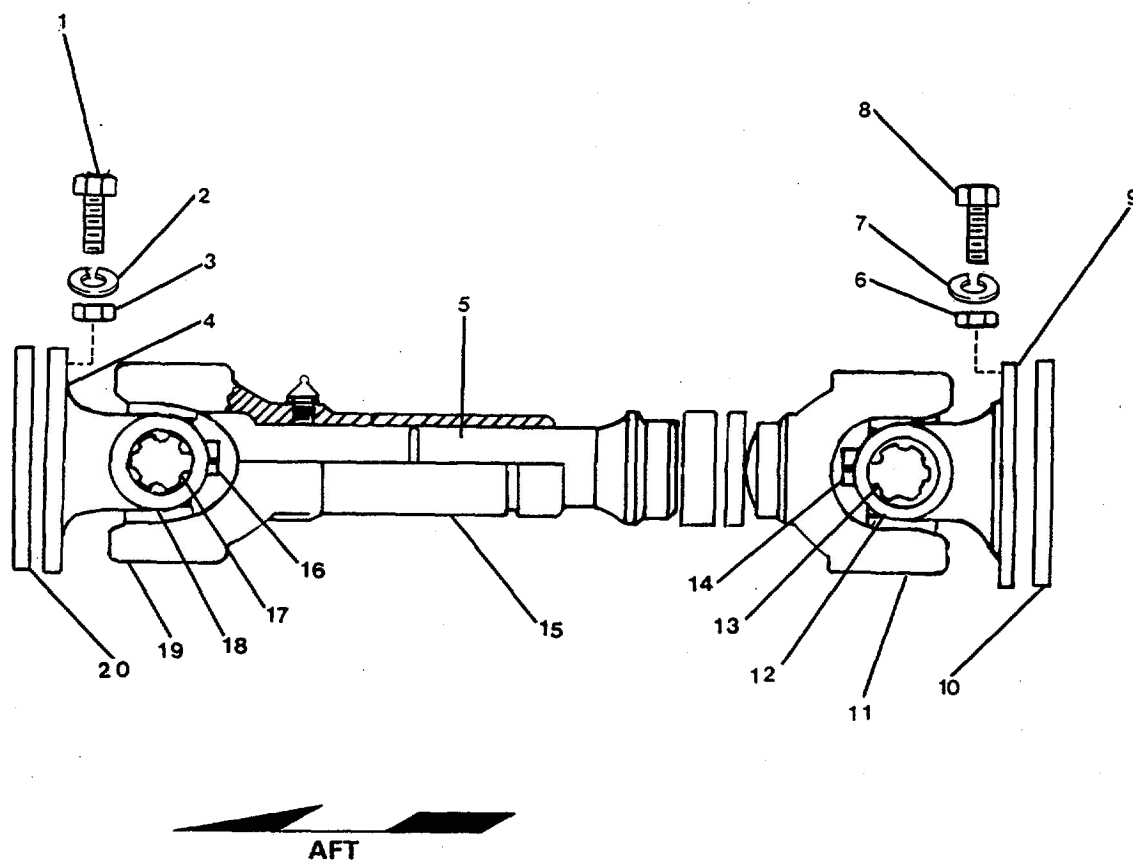

FIGURE 2-5. Drive Shaft.

Section VI. PREPARATION FOR STORAGE OR SHIPMENT

2-15. General. If the bowthruster waterjet will be out of service for an extended period of time (3 weeks or longer), or shipped to another location, certain actions must be taken to protect it against the corrosive effect of the elements. Further information can be found in Army Technical Bulletin TB 740-97-4.

a. Temporary Storage. If the bowthruster water jet is to remain out of service for a maximum of 6 months, the procedures listed below are required to minimize or prevent damage.

(1) Drain the oil tank and hydraulic system in accordance with Table 2-1, Items 6 and 7. Tank may remain empty until the equipment is ready for use. Tag with a warning tag indicating that oil has been drained, the date, and that the equipment is not ready for use.

(2) Cover all the openings with heavy paper and tape to prevent the entrance of dirt and moisture.

b. Permanent Storage. When the bowthruster waterjet is to be stored for 6 months or more, the following procedures must be performed:

(1) Repeat step a (1) above.

(2) Fill the oil tank to the full mark with preservative oil, U.S. Military Specification MIL-L-21260, Type.P-10, Grade 2 SAE 30.

(3) Cover all the openings with heavy paper and tape to prevent the entrance of dirt and moisture.

(4) Brush or spray on a film of rust preventive compound on all exposed, unpainted surfaces. Use a rust preventive conforming to Type P-1, Grade 1 or 2, U.S. Military Specification MIL-C-16173C.

(5) Tag to indicate that equipment has been treated with preservatives. The tag should indicate that the oil and hydraulic fluids have been removed, the date of treatment, and that the equipment is not ready to operate.

(6) Store the bowthruster waterjet in an area where the air is dry and temperature uniform.

2-16. Preparation for Use After Storage. When a bowthruster water jet is removed from storage and put into service, the following operations must be performed.

a. Cleaning. Clean the equipment using the following procedure.

(1) Clean accumulated dirt from the exterior of the equipment. Remove the covers, tape, and wrappings.

(2) Use a suitable cleaner to remove the rust preventive compound from the unpainted surfaces.

(3) If required, paint the exterior in accordance with TM 43-0139, Painting Instructions for Field Use.

b. Inspection. Inspect the equipment using the following procedure:

(1) When a bowthruster waterjet has been stored for 6 months or less, tighten capscrews and connections and check hydraulic hoses for cracks, breaks, or other damage.

(2) Refill the lube oil tank with clean oil and clean the air filler cap.

(3) When the equipment has been stored for 6 months or more, the following procedures must be followed in addition to the above.

(a) Flush the lubricating oil system with clean fuel oil until all preservative oil is removed.

(b) Fill with oil as in step b(2).

APPENDIX A

REFERENCES

A-1. Scope. This paragraph lists the manuals, bulletins, specifications, and miscellaneous publications referenced in this manual or required for maintenance activities.

A-2. Field Manuals.

FM 21-11	First Aid for Soldiers
FM 31-70	Basic Cold Weather Manual
FM 55-501	Marine Crewman's Handbook

A-3. Technical Manuals.

TM 43-0139	Painting Instructions for Field Use
TM 55-1905-223-10	Operator's Manual for Landing Craft, Utility (LCU)
TM 55-1905-223-24-18	LCU 2000 Class Basic Craft Maintenance Manual
TM 55-1905-223-24P	Repair Parts and Special Tools List for the LCU 2000 Class Watercraft
TM 750-244-3	Destruction of Army Materiel to Prevent Enemy Use
TM 55-1905-223-24-5	Bowthruuster Engine

A-4. Technical Bulletins.

TB 43-0144	Painting of Vessels
TB 55-1900-207-24	Treatment of Cooling Water in Marine Diesel Engines
TB 740-97-4	Preservation of Vessels for Storage

A-5. Military Specifications.

MIL-C-16173C	Rust Preventive, Type P-1
MIL-L-644	Preservative Oil, Type P-9
MIL-L-21260	Preservative Oil, Type P-10

A-6. Miscellaneous Publications.

DA Pam 738-750	The Army Maintenance Management System
LO 55-1905-223-12	Lubrication Order for the LCU 2000 Class Watercraft
*AMC-R 750-11	Use of Lubricants, Fluids, and Associated Products

A-7. Forms.

DA Form 2028 and DA Form 2028-2	Recommended Changes to Publications and Blank Forms
DA Form 2404	Equipment Maintenance and Inspection Worksheet
DA Form 2408-16	Logsheet
DA Form 2410	Logsheet
SF Form 368	Quality Deficiency Report

* Supersedes Darcom-R 750-11

APPENDIX B MAINTENANCE ALLOCATION CHART

SECTION I. INTRODUCTION

B-1. THE ARMY MAINTENANCE SYSTEM MAC.

a. This introduction (Section I) provides a general explanation of all maintenance and repair functions authorized at various maintenance levels under the standard Army Maintenance System concept.

b. The Maintenance Allocation Chart (MAC) in Section II designates overall authority and responsibility for the performance of maintenance functions on the identified end item or component. The application of the maintenance functions to the end item or component will be consistent with the capacities and capabilities of the designated maintenance levels, which are shown in the MAC in column (4) as:

Unit - includes two subcolumns: C (operator/crew) and O (unit) maintenance.

Direct Support - includes an F subcolumn.

General Support - includes an H subcolumn.

Depot - includes a D subcolumn.

c. Section III lists the tools and test equipment (both special tools and common tools sets) required for each maintenance function as referenced from Section II.

d. Section IV contains supplemental instructions and explanatory notes for a particular maintenance function as referenced from Section II.

B-2. MAINTENANCE FUNCTIONS. Maintenance functions will be limited to and defined as follows:

a. **Inspect.** To determine the serviceability of an item by comparing its physical, mechanical, and/or electrical characteristics with established standards through examination (i.e., by sight, sound, or feel).

b. **Test.** To verify serviceability by measuring the mechanical, pneumatic, hydraulic, or electrical characteristics of an item and comparing those characteristics with prescribed standards.

c. **Service.** Operations required periodically to keep an item in proper operating condition, i.e., to clean (includes decontamination, when required), to replace filters, to preserve, to drain, to paint, or to replenish fuel, lubricants, chemical fluids, or gases.

d. **Adjust.** To maintain or regulate, within prescribed limits, by bringing into proper or exact position, or by setting the operating characteristics to specified parameters.

e. **Align.** To adjust specified variable elements of an item to bring about optimum or desired performance.

f. **Calibrate.** To determine and cause corrections to be made or to be adjusted on instruments or test, measuring, and diagnostic equipment used in precision measurement. Consists of comparisons of two instruments, one of which is a certified standard of known accuracy, to detect and adjust any discrepancy in the accuracy of the instrument being compared.

g. **Remove/Install.** To remove and install the same item when required to perform service or other maintenance functions. Install may be the act of emplacing, seating, or fixing into position a spare, repair part, or module (component or assembly) in a manner to allow the proper functioning of an equipment or system.

h. Replace. To remove an unserviceable item and install a serviceable counterpart in its place. Replace is authorized by the MAC and is shown as the 3rd position code of the SMR code.

i. Repair. The application of maintenance services¹ including fault location/troubleshooting², removal/installation, and disassembly/assembly³ procedures, and maintenance actions⁴ to identify troubles and restore serviceability to an item by correcting specific damage, fault, malfunction, or failure in a part, subassembly, module (component or assembly), and item, or system.

j. Overhaul. That maintenance effort (service/action) prescribed to restore an item to a completely serviceable/operational condition as required by maintenance standards in appropriate technical publications (i.e., DMWR). Overhaul is normally the highest degree of maintenance performed by the Army. Overhaul does not normally return an item to like new condition.

k. Rebuild. Consists of those service/actions necessary for the restoration of unserviceable equipment to a like new condition in accordance with original manufacturing standards. Re-build is the highest degree of material maintenance applied to Army equipment. The rebuild operation includes the act of returning to zero those age measurements (hours, miles, etc.) considered in classifying Army equipment and components.

B-3. EXPLANATION OF COLUMNS IN THE MAC, SECTION II

a. Column 1 - Group Number. Column 1 lists functional group code numbers, the purpose of which is to identify maintenance significant components, assemblies, subassemblies, and modules with the next higher assembly.

b. Column 2 - Component/Assembly. Column 2 contains the names of components, assemblies, subassemblies, and modules for which maintenance is authorized.

c. Column 3 - Maintenance Function. Column 3 lists the functions to be performed on the item listed in column 2 (For detailed explanation of these functions, see paragraph A-2.)

d. Column 4 - Maintenance Category. Column 4 specifies, by the listing of a work time figure in the appropriate subcolumn(s), the category of maintenance authorized to perform the function listed in Column 3. This figure represents the active time required to perform that maintenance function at the indicated category of maintenance. If the number or complexity of the tasks within the listed maintenance function varies at different maintenance categories, appropriate work time figures will be shown for each category. The work time figure represents the average time required to restore an item (assembly, subassembly, component, module, end item, or system) to a serviceable condition under typical field operating conditions. This time includes preparation time (including any necessary disassembly/assembly time), troubleshooting/fault location time, and quality assurance/quality control time in addition to the time required to perform the specific tasks identified for the maintenance functions authorized in the maintenance allocation chart. The symbol designations for the various maintenance categories are as follows:

- C Operator or Crew
- O Unit Maintenance
- F Direct Support Maintenance (DS)
- H General Support Maintenance (GS)
- D Depot Maintenance

¹Service - Inspect, test, service, adjust, align, calibrate, and/or replace.

²Fault location/troubleshooting - The process of, investigating and detecting the cause of equipment malfunctioning;
the act of isolating a fault within a system or unit under test (UUT).

³Disassembly/assembly - The step-by-step breakdown (taking apart) of a spare/functional group coded item to the level of its least component, that is assigned an SMR code for the level of maintenance under consideration (i.e., identification as maintenance significant).

⁴Actions - Welding, grinding, riveting, straightening, facing, machining, and/or resurfacing.

e. Column 5 - Tools and Equipment. Column 5 specifies, by number code, those common tool sets (not individual tools); special tools; Test, Measurement, and Diagnostic Equipment (TMDE); and support equipment required to perform the designated function, which shall be keyed to the tools listed in Section III.

f. Column 6 - Remarks. This column shall, when applicable, contain a letter code, in alphabetic order, which shall be keyed to the remarks contained in Section IV.

B-4. EXPLANATION OF COLUMNS IN TOOL AND TEST EQUIPMENT REQUIREMENTS, SECTION III.

a. Column 1 - Reference Code. The tool and test equipment reference code correlates with a number code used in the MAC, Section II, Column 5.

b. Column 2 - Maintenance Category. The lowest category of maintenance authorized to use the tool or test equipment.

c. Column 3 - Nomenclature. Name or identification of the tool or test equipment.

d. Column 4 - National Stock Number. The National stock number (NSN) of the tool or test equipment.

e. Column 5 - Tool Number. The manufacturer's part number.

B-5. EXPLANATION OF COLUMNS IN REMARKS, SECTION IV.

a. Column 1 - Reference Code. The letter code recorded in Column 6, Section II.

b. Column 2 - Remarks. This column lists information pertinent to the maintenance function being performed as indicated in the MAC, Section II.

**SECTION II. MAINTENANCE ALLOCATION CHART
FOR
BOWTHRUSTER WATERJET**

(1) GROUP NUMBER	(2) COMPONENT ASSEMBLY	(3) MAINTENANCE FUNCTION	(4) MAINTENANCE CATEGORY					(5) TOOLS AND EQUIP	(6) REMARKS
			C	O	F	H	D		
06	SPJ- 55BOWTHRUSTER WATERJET	Inspect	0.5						
		Test	0.5						
		Service	1.5					1-3	
		Repair	1.0	0.7				1-3	D
		Overhaul					*		A
0601	PUMP ASSEMBLY, COMPLETE	Inspect	0.5						
0602	TANK ASSEMBLY, OIL	Inspect	0.5						
		Service	0.5						
		Replace		0.9				1, 2, 4	
		Repair		0.5				1, 2, 4	
0603	AGGREGATE, HYDRAULIC	Inspect	0.5						
		Repair	0.5					1-3	
060301	BASE ASSEMBLY, HYDRAULIC AGGREGATE	Inspect	0.5						
060302	FILTER ASSEMBLY, RETURN, OIL	Inspect	0.5						
		Service	0.5					1, 2	
		Replace	0.5					1, 2	
		Repair		0.8				1, 2	
0604	FEEDBACK UNIT	Inspect	0.5						
		Replace		0.5				1-3	
		Repair		0.5				1-3	B

(1) GROUP NUMBER	(2) COMPONENT ASSEMBLY	(3) MAINTENANCE FUNCTION	(4) MAINTENANCE CATEGORY					(5) TOOLS AND EQUIP	(6) REMARKS
			C	O	F	H	D		
0605	GEAR ASSEMBLY, STEERING, RIGHT	Inspect	0.5					1-3	
		Service	0.5						
0606	GEAR ASSEMBLY, STEERING, LEFT	Inspect	0.5					1-3	
		Service	0.5						
0607	STEERING ASSEMBLY	Inspect	0.5						
060701	HY-MOTOR	Inspect	0.5					1-3	
060702	BRAKE	Inspect	0.5						
0608	UPPER GEAR ASSEMBLY	Inspect	0.5					1-3	
		Service	0.5						
0609	WATERJET ASSEMBLY	Inspect	0.5					1-3	
		Service	0.5						
0610	PUMP, OIL EVACUATION	Inspect	0.5					1-3	
		Service	0.5						
		Replace	1.0						
		Repair		1.0					
0611	SHAFT, DRIVE	Inspect	0.5					1-3	
		Service	0.5						
		Replace	1.0						
		Repair		1.0					
0612	PLUMBING, WATERJET	Inspect	0.5						C

**SECTION III. TOOLS AND TEST EQUIPMENT REQUIREMENTS
FOR
BOWTHRUSTER WATERJET**

TOOL OR TEST EQUIPMENT REF CODE	MAINTENANCE CATEGORY	NOMENCLATURE	NATIONAL/NATO STOCK NUMBER	TOOL NUMBER
1	O	Tool Kit, General Mechanics	5180-00-699-5273	(50980) SC-5180-90-CL-NO5
2	O	Combination Wrench Set, Metric, 10 mm through 24 mm	5120-01-046-4979	
3	O	Torque Wrench Kit		3377216
4	O	Socket Set, Socket Wrench	5120-01-429-3675	318TWMY

**SECTION IV. REMARKS
FOR
BOWTHRUSTER WATERJET**

REFERENCE CODE	REMARKS
A	Depot repair/maintenance will be performed on a case by case basis subject to approval and funding by the National Maintenance Point (NMP).
B	This item is a candidate for direct exchange with vendor.
C	Repair of this item is by replacement.
D	Requires special training, for Direct Support and General Support Maintenance, which is not presently authorized. A change to the manual will be made when authorized.

APPENDIX C

EXPENDABLE/DURABLE SUPPLIES AND MATERIALS LIST

SECTION I. INTRODUCTION

C-1. Scope. This appendix lists expendable supplies and materials needed to operate and maintain the LCU 2000 Class Watercraft. These items are authorized by CTA 50-970, Expendable/Durable Items (except Medical, Class V, Repair Parts and Heraldic Items), or CTA 8-100, Army Medical Department Expendable Items.

C-2. Explanation of Columns.

a. Column (1) - Item Number. This number is assigned to the entry in the listing and is referenced in the narrative instructions to identify the material (for example, "Use cleaning compound, Item 5, App. C").

b. Column (2) - Level. This column identifies the lowest level of maintenance that requires the listed item.

As applicable:

C - Operator/Crew

O - Organizational Maintenance

c. Column (3) - National Stock Number. This is the national stock number assigned to the item; use it to request or requisition the item.

d. Column (4) - Description. Indicates the Federal item name and, if required, a description to identify the item. The last line for each item indicates the Federal Supply Code for Manufacturers (FSCM) in parentheses followed by the part number.



e. Column (5) - Unit of Measure (U/M). Indicates the measure used in performing the actual maintenance function. This measure is expressed by a two-character alphabetical abbreviation (for example, ea, in, pr). If the unit of measure differs from the unit of issue, requisition the lowest unit of issue that will satisfy your requirements.

Section II. EXPENDABLE/DURABLE SUPPLIES AND MATERIALS LIST

(1) ITEM NUMBER	(2) LEVEL	(3) NATIONAL STOCK NUMBER	(4) DESCRIPTION	(5) U/M
1	O	7920-00-205-1711	Rags, Wiping Cotton and Cotton Synthetic 7920-00-205-1711	LB
2	O	6850-00-474-2302	Solvent, Dry Cleaning (81349) MIL-PRF-680	GL
3	O	7920-00-165-7277	Brush, Dusting Bench (45092) 378	EA
4	O	3610-00-371-9660	Cleaning Pan (81336) D298PT22998-2-11	EA
5	O		Warning tags	
6	O	7240-01-512-5235	Utility Pail (58536) A-A-59253-4B	EA
7	O	5970-00-198-8621	Electrical Tape (58536) A-A-2094	IN
8	O	9150-01-197-7693	Grease, Automotive and Artillery (81349) M-10924-B	OZ
9	O		Hydraulic Fluid, Fire Resistant (81349) MIL-PRF-46170	
10	O	9150-01-035-5393	Lubricating Oil, Gear (81349) M2105-3-80W90	GL

APPENDIX D
TORQUE VALUES

Table D-1. Torque Values for Capscrews, Bolts, and Nuts

Nominal Thread Diameter	Torque (ft-lb) for Coarse and Fine Threads				Screws for Universal Joint Bearing Caps Lubricated
	 SAE Grade 5		 SAE Grade 8		
	as Received	Lubri- cated	as Received	Lubri- cated	
1/4	9 + 1	7 + 1	14 + 1	11 + 1
5/16	19 + 2	15 + 2	27 + 2	22 + 2
3/8	33 + 3	27 + 2	46 + 4	38 + 3
7/16	52 + 4	40 + 3	73 + 6	60 + 5	64 + 4
1/2	80 + 6	65 + 5	112 + 8	90 + 7	100
9/16	112 + 8	90 + 8	158 + 12	130 + 10
5/8	158 + 12	130 + 10	224 + 16	180 + 15	190 + 10
3/4	280 + 20	225 + 20	390 + 30	320 + 25	330 + 17
7/8	448 + 32	360 + 30	630 + 50	510 + 40	510 + 25
1	680 + 50	540 + 45	960 + 70	775 + 60
1 1/8	850 + 60	675 + 60	1360 + 100	1100 + 85
1 1/4	1175 + 85	925 + 75	1850 + 150	1500 + 125

GLOSSARY

Section I. ABBREVIATIONS

ac	alternating current
AFC	automatic flow control
ATDC	after top dead center
ATV	automatic trip valve
BDC	bottom dead center
BTDC	before top dead center
cc	cubic centimeter
cfm	cubic feet per minute
cm	centimeter
cm Hg	Centimeters Mercury
CPL	Control Parts List
dc	direct current
DCA	diesel coolant additive
Dir	Direction
ea	each
EFC	electric fuel control
EIR	Equipment Improvement Recommendations
Emer	Emergency
FFC	full flow cooling
ft	foot
ft-lb	foot-pound
Fwd	Forward
H ₂ O	water
Hex	Hexagon
HP	Horsepower
Hz	Hertz
Hy	Hydraulic
Hyd	Hydraulic
id	inside diameter
ILS	Isochronous Load Sharing
in	inch
in ²	square inch
in ³	cubic inch
in-lb	inch-pound
kg	kilogram
kPa	Kilos Pascal (metric equivalent to psi)
kw	kilowatt
lb	pounds
LCU	Landing Craft Utility
Lub	Lubrication
l _m	litres per pound
LVL	Level
Mchry	Machinery
min	Minimum
mm	millimeter
mm Hg	millimeter-mercury

GLOSSARY - CONT

ABBREVIATIONS

N♦m	Newtons
N♦	Newtons-metric (equivalent to ft-lb)
NSN	National stock number
od	outside diameter
PMCS	Preventive Maintenance Checks and Services
P/N	Part number
psi	pounds per square inch
psig	pounds per square inch gauge
PT	pressure time
qt	Quart
rpm	revolutions per minute
Sta	Station
TDC	top dead center
TIR	total indicator reading
u-joint	Universal joint
VAC	volts, alternating current
Vdc	Volts direct current
VS	variable speed

GLOSSARY - CONT**Section II. DEFINITIONS**

AMBIENT TEMPERATURE	-	The atmospheric temperature of the immediate surrounding area.
ANODES	-	Active metals such as zinc and magnesium which, when attached to steel or other metal in a water environment, prevent the corrosion of the metal. The anodes corrode and are sacrificed instead of the steel.
ANTIFREEZE	-	A solution which, when mixed with water, lowers the freezing point.
ALTERNATING CURRENT	-	Electrical current which repeatedly varies from zero to a positive maximum value to zero to a negative maximum value and back to zero at a periodic rate. Since the applied voltage continually reverses polarity, the resultant current flow alternates in direction within the circuit.
AIR GAP	-	The radial space between the rotating and the stationary elements of a generator. The magnetic field passes through this space.
AMMETER	-	An instrument designed to measure electric current.
AMP	-	An abbreviation for the term Ampere.
AMPERE	-	The unit of measure of electrical current flow. One ampere of current will flow when one volt of electrical potential is applied across one ohm of resistance.
CAPACITOR	-	A device possessing the property of capacitance. A typical capacitor consists of two conducting surfaces separated by an insulating material. A capacitor stores electrical energy, blocks the flow of dc, and permits the flow of ac to a degree largely dependent on the capacitance and the frequency of the applied ac.
CIRCUIT	-	An electrical path through which an electric current may flow from a voltage source. A complete circuit is one where current is flowing. An open circuit is one where the path has been disrupted, such as an open switch or circuit breaker, thus stopping current flow.
CIRCUIT BREAKER	-	A protective device for opening a circuit when current when current flow exceeds a predetermined value.

GLOSSARY -CONT

DEFINITIONS - CONT

COOLANT	-	The circulating element, generally fresh water, which carries away the head generated by the friction of moving parts of an engine.
CONDUCTOR	-	A wire, cable, bus, or other device intended to distribute current from the supply to the load. Technically, a conductor is any device which will permit the flow of current.
CONTACTOR	-	A device for opening and closing an electric circuit. Contactors are normally used in motor circuit where large amounts of current are controlled.
CURRENT	-	The flow of electrons in a circuit forced by an applied voltage potential (See Alternating Current and direct Current).
CYCLE	-	A complete set of events before repetition occurs. In alternating current or voltage, a cycle starts at zero, continues to a maximum positive value, returns to zero, continues to a maximum negative value, and is completed at zero.
DIODE	-	A two terminal solid-state device which permits current to flow in one direction, but not in the other. In alternating current circuits, a diode will permit one half cycle to flow but will resist the flow of the opposite half cycle of current. Thus, alternatin-g current is converted to direct current by a diode.
EXCITATION	-	The direct current input to the field coils of a generator which produces the magnetic flux required for inducing voltage into the generator stator coils.
EXCITER	-	An electrical device used for supplying the excitation to the generator field (see Exciter Rotor and Exciter Stator).
EXCITER CURRENT	-	The direct current supplied to the exciter field coils which is controlled by the voltage regulator.
EXCITER ROTOR	-	The rotating member of the exciter into which a three-phase alternating voltage is induced. The resulting ac is then rectified into direct current and applied to the rotating generator field windings.

GLOSSARY - CONT**DEFINITIONS - CONT**

EXCITER STATOR	-	The stationary member of the exciter which serves as the exciter field producing the magnetic field from the direct current supplied by the automatic voltage regulator.
FIELD	-	That part of ,the generator and exciter which, when supplied wi direct current, will produce a magnetic field. The exciter stator serves as the exciter field while the main generator rotor serves as the generator field.
FREQUENCY	-	The number of complete cycles of alternating current per unit of time. Typically, frequency is expressed in cycles per second or Hertz (Hz).
GENERATOR ROTOR	-	The rotating member of the generator.
GENERATOR STATOR	-	The stationary member of the main generator which supplies the three-phase output power to the load.
GLYCOLS	-	A group of chemicals used to lower the freezing point of water.
GOVERNOR	-	A device which controls engine speed and thus the generator output frequency.
GROUND	-	A connection, either accidental or intentional, between an electrical potential and the earth or some conducting body serving in place of the earth.
HEAT SINK	-	A device which absorbs heat from electrical devices such as diodes and SCRs and dissipates the heat to the surrounding air.
HERTZ	-	A term equivalent to cycles per second. (See Frequency).
HUNTING	-	Oscillation in frequency or in voltage where steady-state conditions are not reached, particularly after a load transient change.
INSULATION	-	A non-conductive material such as rubber or plastic intended to prevent current from flowing. Technically, insulation is any material which resists the flow of current.
INSULATION RESISTANCE	-	A measure of the ability of insulation to prevent current from flowing. A megohmmeter is used to measure the resistance in millions of ohms between the windings and metal frame of a generator to determine the insulation resistance of the windings.

GLOSSARY - CONT

DEFINITIONS - CONT

RHEOSTAL	-	A variable resistor.
STATOR	-	The stationary part of a generator or exciter.
VARISTOR	-	A surge suppressor.

ALPHABETICAL INDEX

Subject; Paragraph

Subject; Paragraph

B

Bowthruster Engine Interface; 1-8b

C

Characteristics, Capabilities, and Features; 1-7
 Checking Unpacked Equipment; 2-4
 Common Tools and Equipment; 2-1

D

Destruction of Army Materiel; 1-3
 Disk Brakes; 1-8q
 Drive Shaft; 1-8c
 Drive Shaft
 Assembly; 2-14
 Disassembly; 2-14
 Removal; 2-14
 Repair; 2-14
 Replacement; 2-14

E

Electrical Power; 1-8e

F

Feedback Unit; 1-8a
 Feedback Unit
 Assembly; 2-12
 Disassembly; 2-12
 Repair; 2-12

H

Hull Interface; 1-8a
 Hydraulic Aggregate; 1-8k
 Hydraulic Motors; 1-8p
 Hydraulic Oil Tank; 1-8j
 Hydraulic Pump; 1-81

I

Initial Setup Procedures; 2-5

L

Location and Description of Major Components; 1-8
 Lube Oil System; 1-8i

M

Maintenance Forms, Records, and Reports; 1-2

N

Normal Startup; 2-6

O

Oil Evacuation Pump; 1-8r
 Oil Evacuation Pump
 Removal; 2-13
 Repair; 2-13
 Replacement; 2-13
 Oil Return Filter; 1-8n
 Oil Return Filter Assembly
 Removal; 2-11
 Repair/Service; 2-11
 Replacement; 2-11
 Oil Tank Assembly
 Removal; 2-10
 Repair; 2-10
 Replacement; 2-10

P

Pilot House Interface; 1-8d
 Preparation for Use After Storage; 2-16
 Preparation for Storage or Shipment; 1-5, 2-15
 Preventive Maintenance Checks
 Principles of Operation; 1-10
 Pump Motor; 1-8m

R

Repair Parts; 2-3
 Reporting Equipment Improvements; 1-4

ALPHABETICAL INDEX - CONT

Subject; Paragraph

S

Safety, Care and Handling; 1-9
Scope of Manual; 1-1
Shutdown Procedure; 2-7
Special Tools; 2-2
Startup, Normal; 2-6
Steering Gear; 1-8h
Storage; 2-15, 2-16
Support Equipment; 2-2

T

TMDE; 2-2
Troubleshooting; 2-9

U

Upper Gear Assembly; 1-8f

W

Waterjet Assembly; 1-8g

By Order of the Secretary of the Army:

CARL E. VUONO
General United States Army
Chief of Staff

Official:

WILLIAM J. MEEHAN, II
Brigadier General United States Army
The Adjutant General

DISTRIBUTION:

To be distributed in accordance with DA Form 12-25A, Unit Maintenance requirements for Landing Craft, Utility, LUC-1466, Type III.

☆U.S. GOVERNMENT PRINTING OFFICE : 1993 O - 342-421 (80351)

These are the instructions for sending an electronic 2028

The following format must be used if submitting an electronic 2028. The subject line must be exactly the same and all fields must be included; however, only the following fields are mandatory: 1, 3, 4, 5, 6, 7, 8, 9, 10, 13, 15, 16, 17 and 27.

From: "Whomever" whomever@avma27.army.mil
To: tacom-tech-pubs@tacom.army.mil

Subject DA Form 2028

1. **From:** Joe Smith
2. **Unit:** home
3. **Address:** 4300 Park
4. **City:** Hometown
5. **St:** MO
6. **Zip:** 77777
7. **Date Sent:** 19-OCT-93
8. **Pub no:** 55-1915-200-10
9. **Pub Title:** TM
10. **Publication Date:** 11-APR-88
11. **Change Number:** 12
12. **Submitter Rank:** MSG
13. **Submitter Fname:** Joe
14. **Submitter Mname:** T
15. **Submitter Lname:** Smith
16. **Submitter Phone:** 123-123-1234
17. **Problem:** 1
18. **Page:** 1
19. **Paragraph:** 3
20. **Line:** 4
21. **NSN:** 5
22. **Reference:** 6
23. **Figure:** 7
24. **Table:** 8
25. **Item:** 9
26. **Total:** 123
27. **Text:**

This is the text for the problem below line 27.

RECOMMENDED CHANGES TO PUBLICATIONS AND BLANK FORMS For use of this form, see AR 310-1; the proponent agency is the US Army Adjutant General Center.						Use Part II (reverse) for Repair Parts and Special Tool Lists (RPSTL) and Supply Catalogs/Supply Manuals (SC/SM).	DATE: Date form is filled out.
TO: (Forward to proponent of publication or form) (Include ZIP Code) Mailing address found on title block page.						FROM: (Activity and location) (Include ZIP Code) Your mailing address.	
PART I - ALL PUBLICATIONS (EXCEPT RPSTL AND SC/SM) AND BLANK FORMS							
PUBLICATION/FORM NUMBER: TM X-XXXX-XXX-XXX						DATE: Date of the TM.	TITLE: Title of TM.
ITEM NO.	PAGE NO.	PARA-GRAPH	LINE NO.	FIGURE NO.	TABLE NO.	RECOMMENDED CHANGES AND REASON (Exact wording of recommended change must be given)	
	0019 00 1	3	1	1		Step No. 2 says to secure doors open with locking bar or hooks from where to what? The bars or hooks are not identified.	
	0019 00 4	4	1	1		Step No. 19 states to remove locking bars, pins or hooks from where to what? The bars, pins or hooks are not identified. Where are they stored?	
SAMPLE							
* Reference to line numbers within the paragraph or subparagraph.							
TYPED NAME, GRADE OR TITLE Doe, John, CPL				TELEPHONE EXCHANGE/AUTOVON, PLUS EXTENSION 755-1313		SIGNATURE CPL John Doe	

TO: (Forward to proponent of publication or form) (Include ZIP Code)	FROM: (Activity and location) (Include ZIP Code)	DATE:
---	---	--------------

PART II - REPAIR PARTS AND SPECIAL TOOL LISTS AND SUPPLY CATALOGS/SUPPLY MANUALS

PUBLICATION/FORM NUMBER: TM X-XXXX-XXX-XXX	DATE: Date of the TM.	TITLE: Title of TM.
--	---------------------------------	-------------------------------

PAGE NO.	COLM NO.	LINE NO.	FEDERAL STOCK NUMBER	REFERENCE NO.	FIGURE NO.	ITEM NO.	TOTAL NO. OF MAJOR ITEMS SUPPORTED	RECOMMENDED ACTION

SAMPLE

PART III - REMARKS (Any general remarks or recommendations, or suggestions for improvement of publications and blank forms. Additional blank sheets may be used if more space is needed.)

* Reference to line numbers within the paragraph or subparagraph.

TYPED NAME, GRADE OR TITLE Doe, John, CPL	TELEPHONE EXCHANGE/AUTOVON, PLUS EXTENSION 755-1313	SIGNATURE CPL John Doe
--	--	-------------------------------

RECOMMENDED CHANGES TO PUBLICATIONS AND BLANK FORMS For use of this form, see AR 25-30; the proponent agency is OAASA						Use Part II (<i>reverse</i>) for Repair Parts and Special Tool Lists (RPSTL) and Supply Catalogs/Supply Manuals (SC/SM).	DATE
TO: (<i>Forward to proponent of publication or form</i>) (<i>Include ZIP Code</i>)						FROM: (<i>Activity and location</i>) (<i>Include ZIP Code</i>)	
PART I - ALL PUBLICATIONS (EXCEPT RPSTL AND SC/SM) AND BLANK FORMS							
PUBLICATION/FORM NUMBER TM 55-1905-223-24-6					DATE 17 JANUARY 1989	TITLE BOWTHRUSTER WATERJET FOR LANDING CRAFT, UTILITY (LCU)	
ITEM	PAGE	PARA-	LINE	FIGURE NO.	TABLE	RECOMMENDED CHANGES AND REASON	
TYPED NAME, GRADE OR TITLE					TELEPHONE EXCHANGE/AUTOVON, PLUS EXTENSION		SIGNATURE

TO: <i>(Forward direct to addressee listed in publication)</i>	FROM: <i>(Activity and location) (Include ZIP Code)</i>	DATE
---	--	-------------

PART II - REPAIR PARTS AND SPECIAL TOOL LISTS AND SUPPLY CATALOGS/SUPPLY MANUALS

PUBLICATION NUMBER TM 55-1905-223-24-6	DATE 17 JANUARY 1989	TITLE BOWTHRUSTER WATERJET FOR LANDING CRAFT, UTILITY (LCU)
--	--------------------------------	--

PAGE NO.	COLM NO.	LINE NO.	NATIONAL STOCK NUMBER	REFERENCE NO.	FIGURE NO.	ITEM NO.	TOTAL NO. OF MAJOR ITEMS SUPPORTED	RECOMMENDED ACTION

PART III - REMARKS *(Any general remarks or recommendations, or suggestions for improvement of publications and blank forms. Additional blank sheets may be used if more space is needed.)*

TYPED NAME, GRADE OR TITLE	TELEPHONE EXCHANGE/AUTOVON, PLUS EXTENSION	SIGNATURE
-----------------------------------	---	------------------

RECOMMENDED CHANGES TO PUBLICATIONS AND BLANK FORMS For use of this form, see AR 25-30; the proponent agency is OAASA						Use Part II (reverse) for Repair Parts and Special Tool Lists (RPSTL) and Supply Catalogs/Supply Manuals (SC/SM).	DATE
TO: (Forward to proponent of publication or form) (Include ZIP Code)						FROM: (Activity and location) (Include ZIP Code)	
PART I - ALL PUBLICATIONS (EXCEPT RPSTL AND SC/SM) AND BLANK FORMS							
PUBLICATION/FORM NUMBER TM 55-1905-223-24-6					DATE 17 JANUARY 1989	TITLE BOWTHRUSTER WATERJET FOR LANDING CRAFT, UTILITY (LCU)	
ITEM	PAGE	PARA-	LINE	FIGURE NO.	TABLE	RECOMMENDED CHANGES AND REASON	
TYPED NAME, GRADE OR TITLE					TELEPHONE EXCHANGE/AUTOVON, PLUS EXTENSION		SIGNATURE

TO: <i>(Forward direct to addressee listed in publication)</i>	FROM: <i>(Activity and location) (Include ZIP Code)</i>	DATE
---	--	-------------

PART II - REPAIR PARTS AND SPECIAL TOOL LISTS AND SUPPLY CATALOGS/SUPPLY MANUALS

PUBLICATION NUMBER TM 55-1905-223-24-6	DATE 17 JANUARY 1989	TITLE BOWTHRUSTER WATERJET FOR LANDING CRAFT, UTILITY (LCU)
--	--------------------------------	--

PAGE NO.	COLM NO.	LINE NO.	NATIONAL STOCK NUMBER	REFERENCE NO.	FIGURE NO.	ITEM NO.	TOTAL NO. OF MAJOR ITEMS SUPPORTED	RECOMMENDED ACTION

PART III - REMARKS *(Any general remarks or recommendations, or suggestions for improvement of publications and blank forms. Additional blank sheets may be used if more space is needed.)*

TYPED NAME, GRADE OR TITLE	TELEPHONE EXCHANGE/AUTOVON, PLUS EXTENSION	SIGNATURE
-----------------------------------	---	------------------

RECOMMENDED CHANGES TO PUBLICATIONS AND BLANK FORMS For use of this form, see AR 25-30; the proponent agency is OAASA						Use Part II (reverse) for Repair Parts and Special Tool Lists (RPSTL) and Supply Catalogs/Supply Manuals (SC/SM).	DATE
TO: (Forward to proponent of publication or form) (Include ZIP Code)						FROM: (Activity and location) (Include ZIP Code)	
PART I - ALL PUBLICATIONS (EXCEPT RPSTL AND SC/SM) AND BLANK FORMS							
PUBLICATION/FORM NUMBER TM 55-1905-223-24-6						DATE 17 JANUARY 1989	TITLE BOWTHRUSTER WATERJET FOR LANDING CRAFT, UTILITY (LCU)
ITEM	PAGE	PARA-	LINE	FIGURE NO.	TABLE	RECOMMENDED CHANGES AND REASON	
TYPED NAME, GRADE OR TITLE						TELEPHONE EXCHANGE/AUTOVON, PLUS EXTENSION	
						SIGNATURE	

TO: <i>(Forward direct to addressee listed in publication)</i>	FROM: <i>(Activity and location) (Include ZIP Code)</i>	DATE
---	--	-------------

PART II - REPAIR PARTS AND SPECIAL TOOL LISTS AND SUPPLY CATALOGS/SUPPLY MANUALS

PUBLICATION NUMBER TM 55-1905-223-24-6	DATE 17 JANUARY 1989	TITLE BOWTHRUSTER WATERJET FOR LANDING CRAFT, UTILITY (LCU)
--	--------------------------------	--

PAGE NO.	COLM NO.	LINE NO.	NATIONAL STOCK NUMBER	REFERENCE NO.	FIGURE NO.	ITEM NO.	TOTAL NO. OF MAJOR ITEMS SUPPORTED	RECOMMENDED ACTION

PART III - REMARKS *(Any general remarks or recommendations, or suggestions for improvement of publications and blank forms. Additional blank sheets may be used if more space is needed.)*

TYPED NAME, GRADE OR TITLE	TELEPHONE EXCHANGE/AUTOVON, PLUS EXTENSION	SIGNATURE
-----------------------------------	---	------------------

The Metric System and Equivalents

Linear Measure

1 centimeter = 10 millimeters = .39 inch
 1 decimeter = 10 centimeters = 3.94 inches
 1 meter = 10 decimeters = 39.37 inches
 1 dekameter = 10 meters = 32.8 feet
 1 hectometer = 10 dekameters = 328.08 feet
 1 kilometer = 10 hectometers = 3,280.8 feet

Weights

1 centigram = 10 milligrams = .15 grain
 1 decigram = 10 centigrams = 1.54 grains
 1 gram = 10 decigrams = .035 ounce
 1 dekagram = 10 grams = .35 ounce
 1 hectogram = 10 dekagrams = 3.52 ounces
 1 kilogram = 10 hectograms = 2.2 pounds
 1 quintal = 100 kilograms = 220.46 pounds
 1 metric ton = 10 quintals = 1.1 short tons

Liquid Measure

1 centiliter = 10 milliliters = .34 fl. ounce
 1 deciliter = 10 centiliters = 3.38 fl. ounces
 1 liter = 10 deciliters = 33.81 fl. ounces
 1 dekaliter = 10 liters = 2.64 gallons
 1 hectoliter = 10 dekaliters = 26.42 gallons
 1 kiloliter = 10 hectoliters = 264.18 gallons

Square Measure

1 sq. centimeter = 100 sq. millimeters = .155 sq. inch
 1 sq. decimeter = 100 sq. centimeters = 15.5 sq. inches
 1 sq. meter (centare) = 100 sq. decimeters = 10.76 sq. feet
 1 sq. dekameter (are) = 100 sq. meters = 1,076.4 sq. feet
 1 sq. hectometer (hectare) = 100 sq. dekameters = 2.47 acres
 1 sq. kilometer = 100 sq. hectometers = .386 sq. mile

Cubic Measure

1 cu. centimeter = 1000 cu. millimeters = .06 cu. inch
 1 cu. decimeter = 1000 cu. centimeters = 61.02 cu. inches
 1 cu. meter = 1000 cu. decimeters = 35.31 cu. feet

Approximate Conversion Factors

<i>To change</i>	<i>To</i>	<i>Multiply by</i>	<i>To change</i>	<i>To</i>	<i>Multiply by</i>
inches	centimeters	2.540	ounce-inches	newton-meters	.007062
feet	meters	.305	centimeters	inches	.394
yards	meters	.914	meters	feet	3.280
miles	kilometers	1.609	meters	yards	1.094
square inches	square centimeters	6.451	kilometers	miles	.621
square feet	square meters	.093	square centimeters	square inches	.155
square yards	square meters	.836	square meters	square feet	10.764
square miles	square kilometers	2.590	square meters	square yards	1.196
acres	square hectometers	.405	square kilometers	square miles	.386
cubic feet	cubic meters	.028	square hectometers	acres	2.471
cubic yards	cubic meters	.765	cubic meters	cubic feet	35.315
fluid ounces	milliliters	29.573	cubic meters	cubic yards	1.308
pints	liters	.473	milliliters	fluid ounces	.034
quarts	liters	.946	liters	pints	2.113
gallons	liters	3.785	liters	quarts	1.057
ounces	grams	28.349	liters	gallons	.264
pounds	kilograms	.454	grams	ounces	.035
short tons	metric tons	.907	kilograms	pounds	2.205
pound-feet	newton-meters	1.356	metric tons	short tons	1.102
pound-inches	newton-meters	.11296			

Temperature (Exact)

°F	Fahrenheit temperature	5/9 (after subtracting 32)	Celsius temperature	°C
----	------------------------	----------------------------	---------------------	----

